

USER MANUAL

tubular motor Ø 45 mm with electronic limit switch and integrated radio receiver

KROG
(Ø 45 mm)

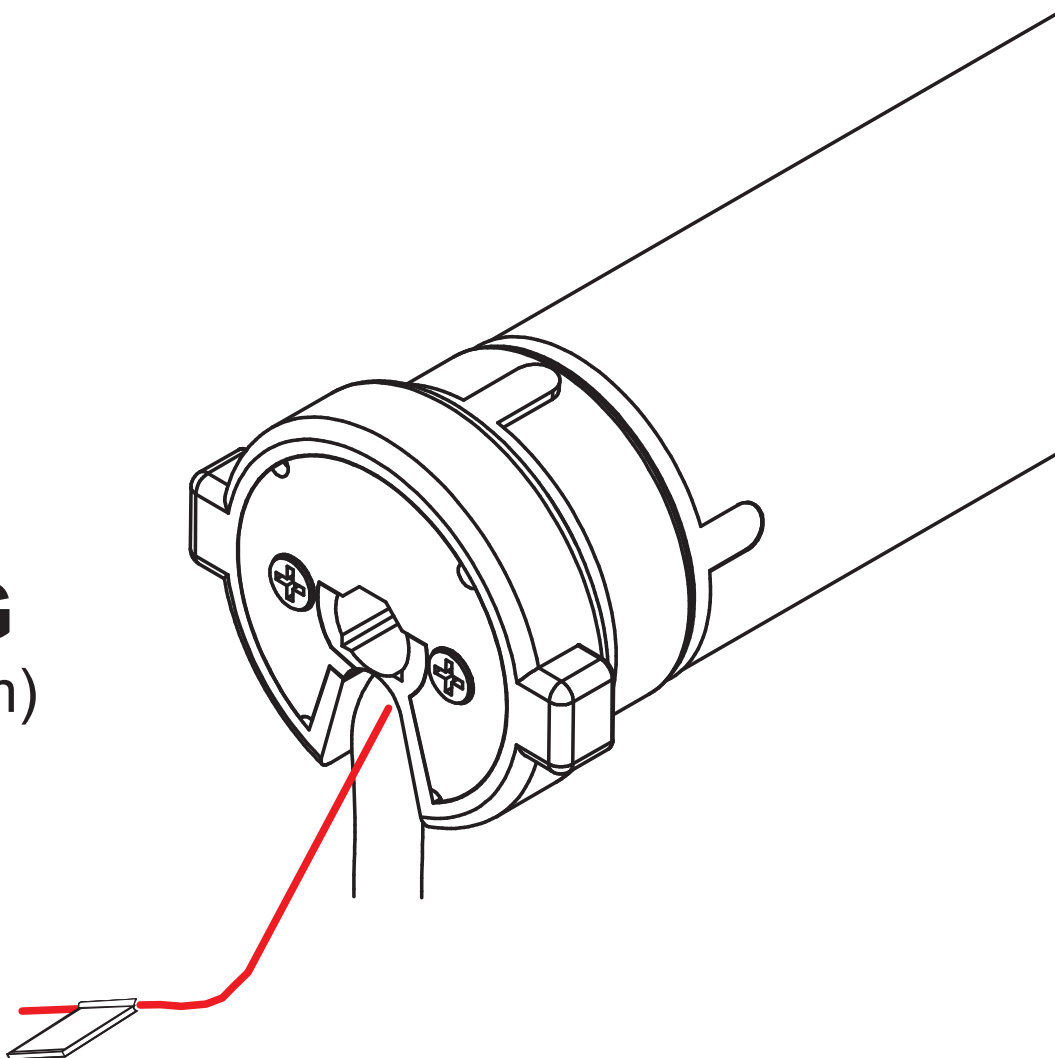

READ CAREFULLY THE MANUAL before starting the installation.

READ CAREFULLY and fully all the warnings.

**We recommend that you read a procedure before running it:
this in order to facilitate the execution and avoid mistakes.**

Keep this manual for future reference.



Dear Customer, Thank you for purchasing a Corradi product . This manual describes the operations necessary for the proper installation of the motor with electronic limit switches model Krog.
The tubular motor with electronic limit switches KROG series are suitable for handling the main types of roller, particularly if manual or automatic hooks are present near the low limit switch.
The technical characteristics are provided on the label stuck on motor. These devices have not been studied for a continuous working. Any other use is improper and forbidden and it could void manufacturer's warranty. The manufacturer cannot be considered responsible for any damage due to improper, wrong or unreasonable use.
The installation of the product must be done by a qualified technician. At the end of the installation, all manuals must be given to the end user.
Keep this manual for future reference!

Rispettiamo l'ambiente

Environmental conservation is an everyone's duty!

MASTER uses packaging recyclable materials. Dispose materials on the proper containers, complying with the law in force in your locality.

If you are an installer and you use many motors, please ask for cavaties box packaging to your retailer or to the manufacturer, this is an environmental respectful choice, that limits waste and considerably reduce the packaging materials.

This product may have substances that are polluting for the environment and dangerous for the health. At the end of the product life cycle, carefully comply with the waste disposal rules. It is strickly forbidden to dispose the product on the domestic waste.



Index

01. Technical specifications	Pag. 02
02. Warnings	Pag. 03
03. Notes on radio systems	Pag. 03
04. Assembly instruction	Pag. 04
05. Canvas change	Pag. 04
06. Electrical connections	Pag. 04
07. Installation procedure using command buttons	Pag. 06
08. Installation procedure using an hand held transmitter	Pag. 07
09. Logic operations of the motor	Pag. 08
10. Memorization/deletion of a radio device	Pag. 09
11. Fine adjustment of upper limit switch	Pag. 10
12. Fine adjustment of lower limit switch	Pag. 10
13. Modify both limit switches	Pag. 10
14. Intermediate limit switch	Pag. 11
15. Sun, wind and rain sensor	Pag. 11
16. Logic of command buttons	Pag. 12
17. Test radio function	Pag. 13
18. Obstacle detection on downward	Pag. 14
19. Traction on upper stop	Pag. 15
20. Traction on hooks	Pag. 16
21. Autozero mode	Pag. 17
22. Error messages and recovery operation	Pag. 18
23. Reset	Pag. 19

01. TECHNICAL SPECIFICATIONS

The technical characteristics of the motor are shown in the label applied to the motor tube. Before installing the motor, it is recommended to copy the technical data (including the full name of the product) and store them in a safe place. These data may be useful in the event of subsequent maintenance or technical assistance. In addition to the technical data on the motor tube (depending on the specific power of the engine), the common characteristics of the motor family KROG are:

Power supply	: 230 Vac 50 Hz	IP insulation	: IP44	Working frequency	: 433.42 MHz
Stand-by consumption	: < 1W	Insulation class	: H	Memorizable transmitters	: 40 (*)
Min. roller diameter KROG	: 50 x 1.5 mm	Max limit switch turns	: ∞	Memorizable wind radio sensor	: 4
		Continuous working time	: 4 minutes	Memorizable sun radio sensor	: 1

(*) not including wind/sun radio sensors

02. WARNINGS

02.1 WARNINGS FOR SAFETY

- ✓ Incorrect installation can cause serious injuries.
- ✓ Keep these instructions for future maintenance work and disposal of the product.
- ✓ All the product installation, connection, programming and maintenance operations must be carried out only by a qualified and skilled technician, who must comply with laws, provisions, local regulations and the instructions given in this manual.
- ✓ The wiring must comply with current IEC standards.
- ✓ Some applications require hold-to-run operation and can exclude the use of radio controls or require particular safety devices.
- ✓ To prevent potentially dangerous situations, check the operating condition of the roller shutter/awning regularly.

02.2 WARNINGS FOR THE INSTALLATION

- ✓ Check that the package is intact and has not been damaged in transit.
- ✓ A heavy knock and the use of unsuitable tools can cause the damage of the external or internal parts of the motor.
- ✓ Do not pierce or tamper with the motor in any way. Do not modify or replace parts without the manufacturer's permission.
- ✓ Do not carry the motor by the power cable. The product may not be used if the power cable is damaged. Do not try to replace the power cable.
- ✓ Any screws needed to complete the installation must not come into contact with the motor.
- ✓ The power of the motor must be sufficient for the applied load (check the rated data shown on the motor).
- ✓ Some stages of programming and/or normal operation make use of the mechanical stops of the roller shutter/awning. It is essential to choose a motor with the most suitable torque for the application, considering the actual traction of the roller shutter/awning, and to avoid motors that are too powerful.
- ✓ Use winding rollers that are at least 1 mm thick.
- ✓ Leave 1-2 mm of right/left play on the winding roller.
- ✓ Check that the shape and size of the drive pulley and adapter crown correspond to the winding roller used. Adapters, supports and sundry accessories related to the motor must be chosen exclusively from the MASTER catalogue.
- ✓ If the product is installed at a height of less than 2.5 m from the floor or from another support surface, the moving parts must be protected with a cover to prevent accidental access. In any case, ensure access for maintenance work.
- ✓ The power cable must be positioned in such a way that it does not come into contact with moving parts.
- ✓ The power cable of the product is suitable for indoor installation only. If installed outside, place the cable in a protective tube.
- ✓ If there are several radio appliances in the same system, they must not be less than 1.5 m apart.
- ✓ Do not install the product near metal surfaces.
- ✓ Position the buttons within sight of the roller shutter/awning but a long way from its moving parts. Position the buttons more than 1.5 m from the floor.
- ✓ The motors are designed for residential use; the maximum continuous operating time is 4 minutes.
- ✓ During operation, the motor body becomes very hot, so be careful.
- ✓ The motor contains a self-resetting thermal cut-out, which stops the motor if it overheats. The motor returns to normal operation when its temperature drops below the safety limit (normally after 5 to 10 minutes).
- ✓ The motor must be installed so that it cannot come into contact with liquids and in any case in a position protected from atmospheric agents.
- ✓ The antenna cable carries line voltage. Do not cut the antenna cable as this would be dangerous. If the antenna cable is damaged, replace the product.
- ✓ For your safety, do not work near the winding roller while the motor is powered.

02.3 WARNINGS FOR USE

- ✓ The product is not intended for use by persons (including children) with reduced physical, sensory or mental capabilities, or lack of experience and knowledge, unless they are supervised or given instructions on how to use the product by a person responsible for their safety.
- ✓ Before operating the roller shutter/awning, make sure there are no people or objects in the area involved in its movement. Check the automation during movement and keep people at a safe distance, until the movement ends.
- ✓ Do not allow children to play with the appliance or with the fixed control devices. Also, keep the portable control devices (remote controls) out of the reach of children.
- ✓ Do not operate the roller shutter/awning when maintenance operations are being carried out (e.g. window cleaning). If the control device is automatic, disconnect the motor from the power line.



03. NOTES ON RADIO SYSTEM



It is advisable to **avoid using radio systems in areas with strong interference** (for example, near police stations, airports, ports, hospital, etc.). A technical inspection is in any case advisable before installing any radio system in order to identify sources of interference. Radio systems can be used where possible disturbances or malfunctioning of the transmitter or the receiver do not cause a risk factor, or if the risk factor is cancelled by suitable safety systems. The presence of radio device operating on the same transmission frequency (**433,42 MHz**) can interfere with the radio receiver of the motor and so reduce the range of the system and limit the functionality of the installation.

WARNING

Potential RADIO interference

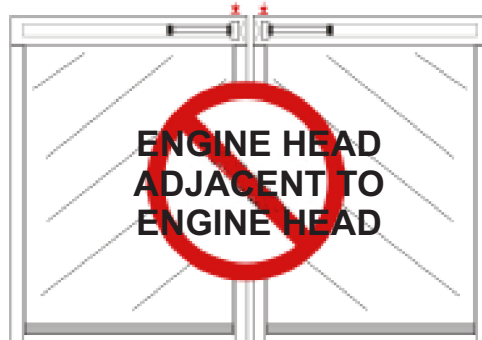

Restricted potential RADIO interference



04. ASSEMBLY INSTRUCTION

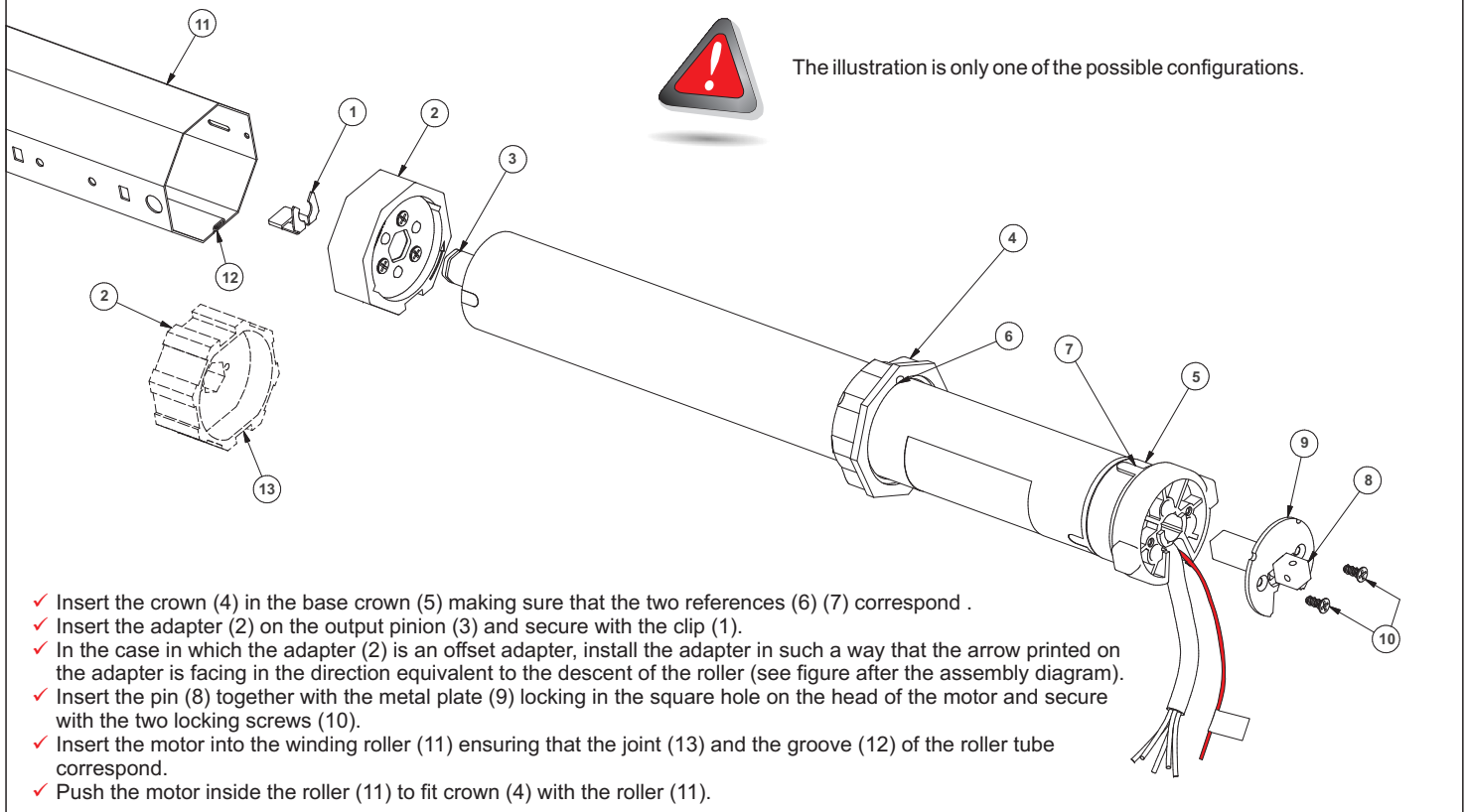

05. CANVAS CHANGE

Warning: If changing the canvas, it is **STRICTLY FORBIDDEN** to leave the motor coupled to the support bracket

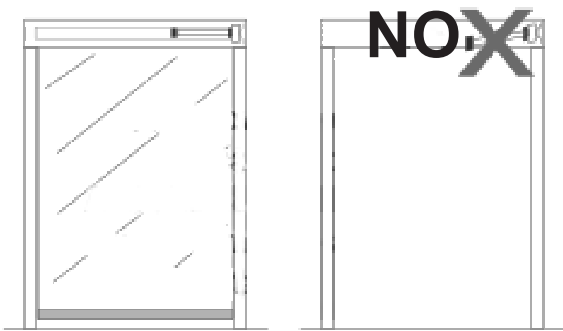

SUPPLY CABLE EXIT TO PREVENT WATER INFILTRATION

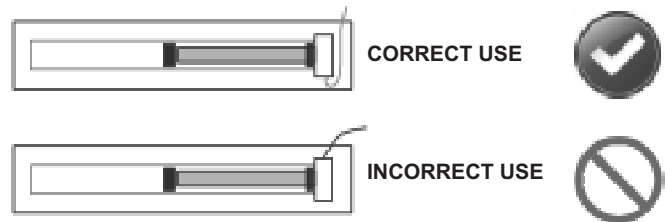

06. ELECTRICAL CONNECTION

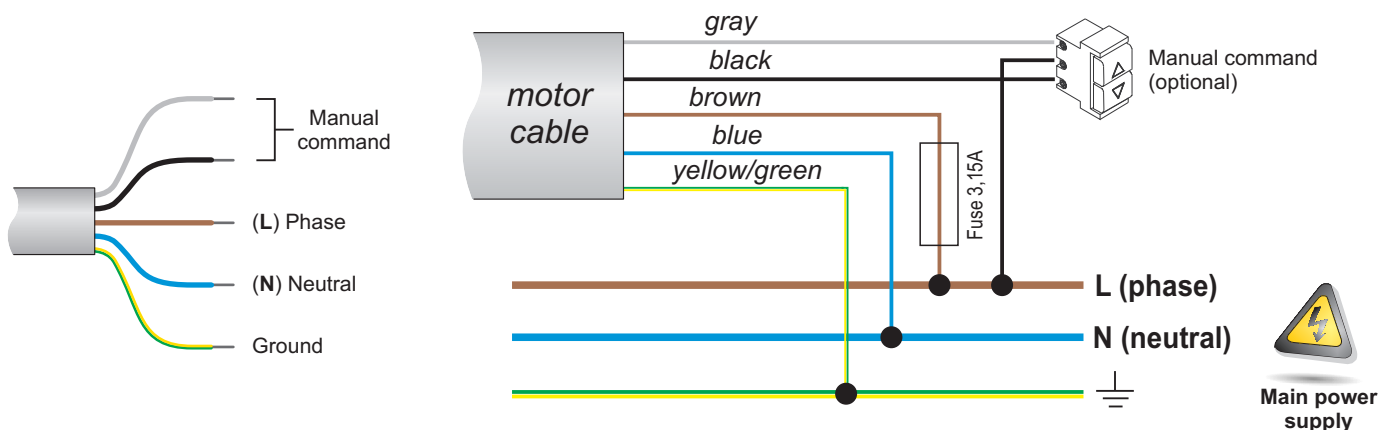

06.1 WARNINGS

- ✓ Make connections with power supply disconnected.
- ✓ Check that the power supply line doesn't depend from electrical circuits for lighting.
- ✓ The supply line must be equipped with a circuit breaker. The installer must fit an isolation device (with 3 mm minimum opening on the contacts) upstream of the system.
- ✓ The section of the connecting cables must be proportionate to their length and to the absorption of the load, and in any case not less than 1.5 mm.
- ✓ The product doesn't provide any protection against overloads or short circuits. You must provide, on the supply line, an adequate protection to the load, for example a rapid fuse of maximum value 3.15 A.
- ✓ You must use buttons with spring return ("hold-to-run" type), do not use buttons with maintained position
- ✓ Command buttons are connected to the main voltage, so they must be properly insulated and protected.

06.2 POWER SUPPLY

The supply voltage must be applied to the brown (PHASE) and blue (NEUTRAL) wires.
Connect the green / yellow wire to the grounding system.
The electrical specifications for motor operation are shown in the label applied to the tube of the motor.

06.3 COMMAND BUTTONS

The control buttons are required if motor is not equipped with a radio receiver (PATH and CORE); are optional if motor is equipped with radio receiver (ATOM and LEG).

The command buttons must be connected to the black and gray wires and they must close on brown wire. **You must use buttons with spring return ("hold to run" type)**, do not use buttons with maintained position. More command buttons can be connected via a parallel connection. The control buttons are subject to the mains voltage and therefore should be properly insulated and protected. In the case where the command buttons are not used, it is necessary to ensure the isolation of black and gray wires.

06.4 MOTOR CONNECTION TO A HOME AUTOMATION CONTROL UNIT

There are different types of home automation control unit (following H.A.C.U.). Some H.A.C.U. allow you to program the time of closing of the output contacts, while others do not allow it; some H.A.C.U. measure the current consumption of the devices applied to the output contacts, while others do not; some H.A.C.U. work with proprietary protocols, while others work with "standard" protocols (eg KNX, Modbus, ...). Because of the diversity of the characteristics of the H.A.C.U. on market, the motor manufacturer can not know if the motor is compatible with the installed H.A.C.U. The control outputs of the H.A.C.U. must be connected to the command inputs of the motor (GREY and BLACK wires), replacing the manual buttons. Consequently, the H.A.C.U. must comply with the rules of operation of the command buttons, depending on whether the command buttons work in PULSE mode (factory setting) or in HOLD TO RUN mode (see section 17 "Logic of commands").

Rules that the H.A.C.U. must comply to control the motors operating with buttons in PULSE mode.

- The H.A.C.U. must not measure the current drawn by the command inputs of the motor (which absorb less than 1 mA).
- The H.A.C.U. must be connected to the motor as shown, substituting the command buttons with the outputs of the H.A.C.U..
- To operate the motor, the H.A.C.U. must close contact (up or down) for more than 0.5 seconds (typically using a pulse duration of 1 second).
- To stop the motor, the H.A.C.U. must close contact (up or down) for 0.5 seconds or less (typically using a pulse duration of 0.2 seconds).

Rules that the H.A.C.U. must comply to control the motors operating with buttons in HOLD TO RUN mode.

- The H.A.C.U. must not measure the current drawn by the command inputs of the motor (which absorb less than 1 mA).
- The H.A.C.U. must be connected to the motor as shown, substituting the command buttons with the outputs of the H.A.C.U..
- To allow the conclusion of the entire opening / closing, the H.A.C.U. must be able to close the contact UP / DOWN to the time required for the motor to perform the complete operation.
- To stop the motor, the H.A.C.U. must be able to re-open the contacts UP / DOWN at any time.

At the time of this document printing, specific issues related to the connection between MASTER products and H.A.C.U. are not known (if you follow the rules above). However MASTER disclaims any responsibility concerning the non-compatibility (even partial) with any H.A.C.U.. If the H.A.C.U. uses KNX protocols or similar, contact the vendors of home automation controller informing them of the rules above. Probably the manufacturer of H.A.C.U. can provide appropriate interfaces to connect the motor to the H.A.C.U..



In the case in which the connection between the H.A.C.U. and motor is not possible or there is some problems, it may be convenient to apply to the control outputs of the H.A.C.U. a suitable transmitting device (MIR DCT) that will be tuned subsequently to the motor to be controlled. For more information, contact your dealer.

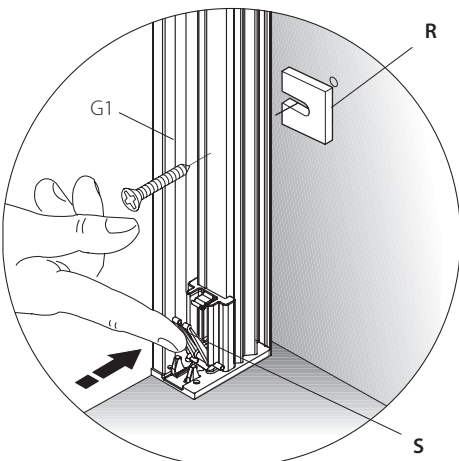

AUTOMATIC HOOKS (FOR PUSH-BUTTON COMMAND AND REMOTE CONTROL)

At the starting programming of the motor, press the lever (S) keeping it in the closed position; open it once the filling is complete.

open

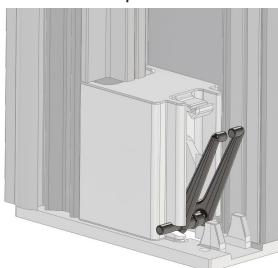

closed

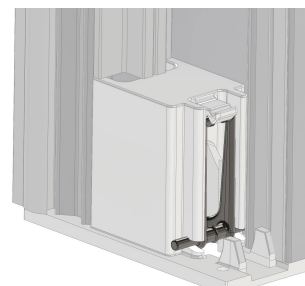

07. INSTALLATION PROCEDURE USING COMMAND BUTTONS



We recommend that you read the entire procedure before performing these steps, in such a way as to make the execution of the procedure easier and with less chance of error.

A

Supply the motor

B (1)

Bring the motor in an intermediate position

C (2)

Press **3 TIMES** the button that MOVES THE MOTOR DOWN

D (3) THE MOTOR STARTS TO MAKE SHORT MOVEMENTS UPWARD
(if the motor makes an alternate movement up / down, repeat step C)

NO hooks	→	after the 1st movement press briefly a button
MANUAL hooks	→	after the 2nd movement press briefly a button
AUTOMATIC hooks	→	after the 3rd movement press briefly a button

E (4)

The motor moves downward

F

Offset adapter? → YES → Wait automatic stop (or stop manually)

NO → Stop manually

Fine adjustment required? → YES → See point M

NO → Wait 10 seconds

G

The motor moves upward

H

Upper end by obstacle? → NO → Stop manually

YES → Wait automatic stop (go to point I)

Fine adjustment required? → YES → See point M

NO → Wait 10 seconds

I

The motor moves 1 time downward and 2 times upward.

L (5)

Storing a transmitter? → YES → WITHIN 15 seconds → Press **STOP** of the transmitter → The motor makes a brief upward movement

NO → Wait 15 seconds → The motor makes 2 brief downward movements

END of installation

Notes:

- ✓ (1): the motor is in "hold to run" mode: the motor moves in a certain direction until you release the button.
- ✓ (2): the button must be pressed for 3 times briefly, about 1 second between each press and the next. **If the button is pressed a number other than 3 times, the motor performs an error message (one movement up, one movement down).** If this happens, repeat point C.
- ✓ (3): elapse about 5 seconds between one movement and the next.
If no option is selected, the motor makes a short downward movement. In this case, repeat step 07.C.
- ✓ (4): by this time the motor moves in 'impulse' mode: to operate the motor press the button for at least 0.5 seconds; to stop the motor press briefly (less than 0.5 seconds) any button.
- ✓ (5): you can memorize the transmitter even later (see Section 10.1, "Memorization - deletion of a radio device").
- ✓ (6): UP and DOWN buttons must be pressed simultaneously and briefly, about 1 second; during the process of fine tuning, while holding down a button, the motor makes small movements in the selected direction.

M (6) FINE ADJUSTMENT

Press together UP and DOWN

Make a fine adjustment

Press together UP and DOWN

08. INSTALLATION PROCEDURE USING AN HAND-HELD TRANSMITTER



We recommend that you read the entire procedure before performing these steps, in such a way as to make the execution of the procedure easier and with less chance of error.

This motor is compatible with ARCO, VISIO, FLUTE and equivalent transmitters.

Before starting the programming procedure, read the instruction manual of the transmitter and locate the buttons UP, STOP, DOWN, PROG necessary for the programming of the motor.

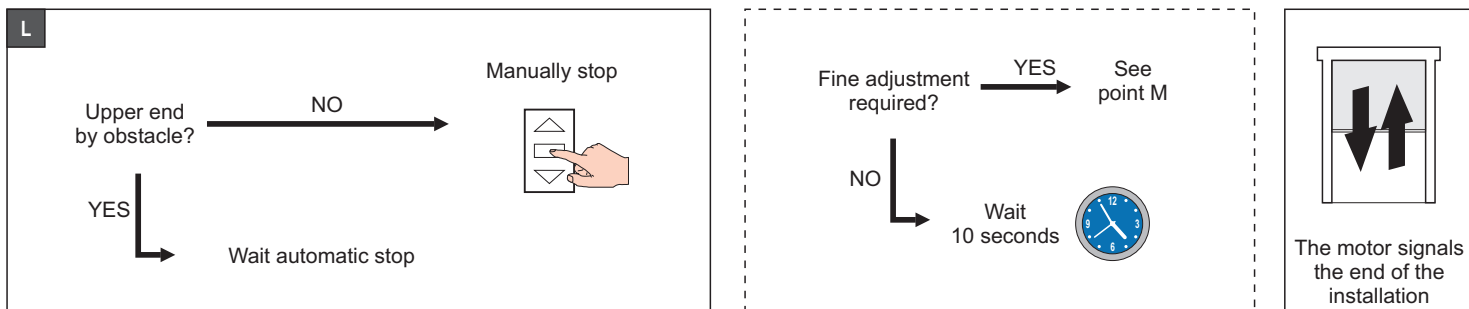
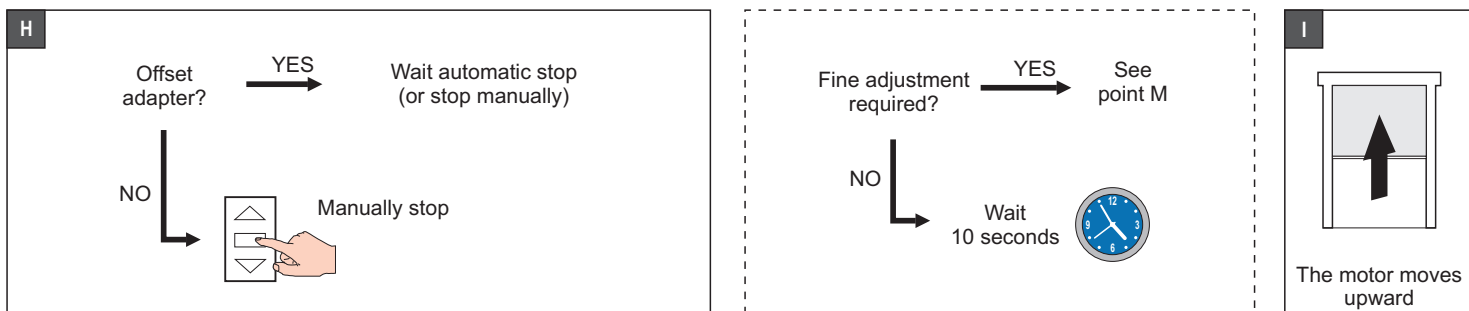
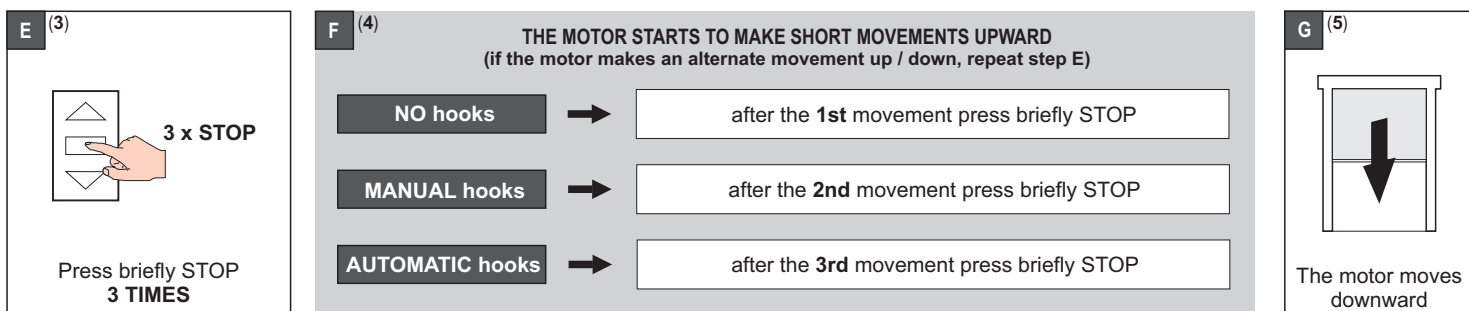
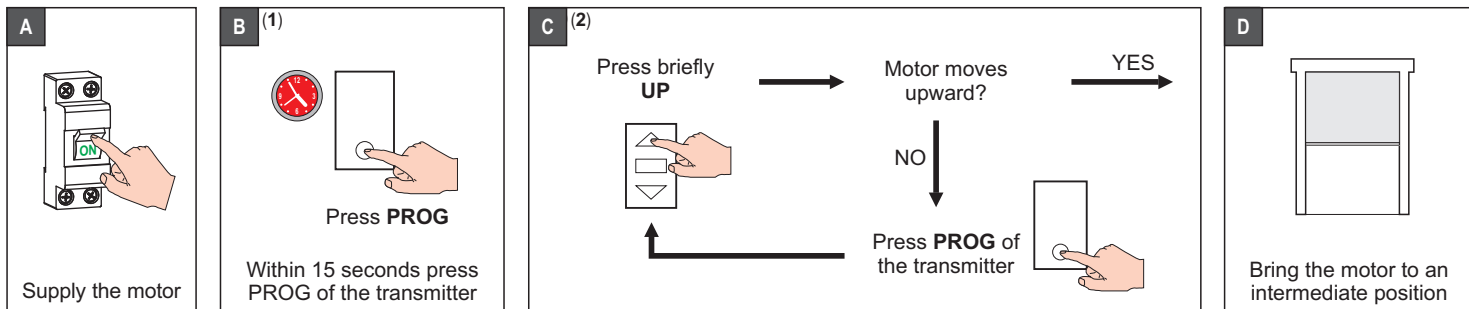

Notes:

- ✓ (1): do not use via cable commands. From the moment you press PROG, the wired controls are disabled.
- ✓ (2): the motor is in "hold to run" mode: the motor moves in a certain direction until you release the button.
- ✓ (3): the STOP button must be pressed for 3 times briefly, about 1 second between each press and the next. **If the button is pressed a number other than 3 times, the motor performs an error message (one movement up, one movement down).** If this happens, repeat step E.
- ✓ (4): elapse about 5 seconds between one movement and the next.
If no option is selected, the motor makes a short downward movement. In this case, repeat step E
- ✓ (5): by this time the motor moves in 'impulse' mode.
- ✓ (6): during the process of fine tuning, while holding down a button, the motor makes small movements in the selected direction.

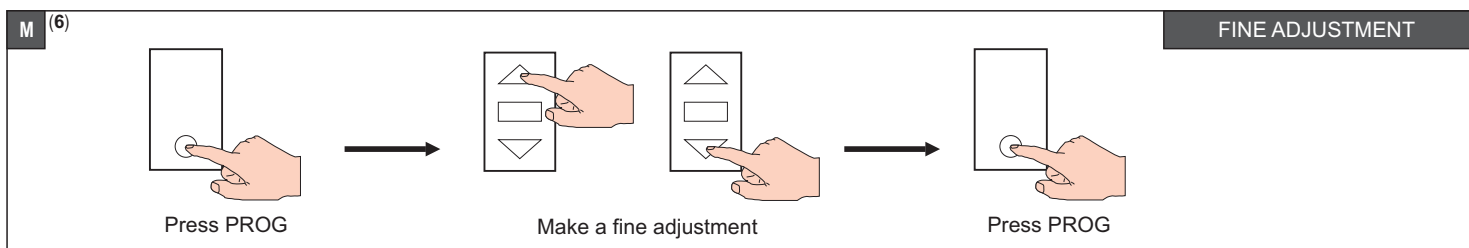

09. LOGIC OPERATION OF THE MOTOR

KROG is designed for the handling of roller blinds without tension hooks, or fitted with manual hooks, or fitted with hooks with automatic hooking / unhooking. In presence of hooks, they must be installed at a maximum distance of 20 cm from the lower end.

09.1 «NO HOOKS» MODE

There is no management of safety hooks. If the motor during upward movement finds an obstacle, the motor makes a brief downward motion to decrease the traction on fabric.

09.2 «MANUAL HOOKS» MODE

If during the upward movement, the motor encounters an obstacle in the vicinity of the lower limit switch, the motor interprets the obstacle such as the presence of the manual hooks, stops the upward movement and keeps the fabric taut. The UP command is inhibited. Commanding a downward movement the motor goes to the lower limit switch allowing you to manually disable the hooks. During the short manoeuvre engagement / release (maximum 3 seconds) the manual controls are inhibited.

09.3 «AUTOMATIC HOOKS» MODE

If during the upward movement, the motor encounters an obstacle in the vicinity of the lower limit switch, the motor interprets the obstacle such as the presence of the automatic hooks, stops the upward movement and keeps the fabric taut. The DOWN command is inhibited. Commanding an upward movement the motor goes to the lower limit switch, then moves upward thus allowing automatic release from the hooks. During the short manoeuvre engagement / release (maximum 3 seconds) the manual controls are inhibited. In the event that unhooking is not to be successful, the motor try again the disengage for a maximum of 3 times, then remains in the engagement position.

note:

any issues relating to the phase of engagement / release of the hooks must be search in their installation or in their mechanical characteristics. The motor in fact performs the standard manoeuvre required for the engagement / release of the most common latches on the market. The motor manufacturer declines all liability due to malfunction of the automatic hooks.

09.4 OBSTACLE DETECTION ON UPWARD

The engine is able to detect the presence of an obstacle during the upward manoeuvre. If the obstacle is interpreted as a hook, the motor stops and keeps the fabric in tension. If the obstacle is detected in such a position that it can not be a hook, the motor stops the upward movement and performs a quick downward movement to free the structure by traction.

09.5 OBSTACLE DETECTION ON DOWNWARD

Only if offset adapter is properly installed, the motor is able to detect the presence of obstacles during the downward movements. If the motor detects an obstacle, the operation is stopped and the motor performs a wide upward movement to allow removal of the obstacle. During this manoeuvre, the manual controls are disabled. The motor is able to detect obstacles that stop instantly the roller blind (ie such as to block firmly the operation); obstacles that block the roller shutter only partially might not be detected by the motor.

If necessary, you can inhibit this properties (see point 18 "Obstacle detection on downward").

09.6 COMPATIBILITY WITH RADIO SENSOR

The motor is compatible with sun / wind / rain radio sensors (for compatible models please contact your supplier). The use of radio sensors and other automatic control devices is not recommended if the roller is provided with latches. The presence of the manual hook, or a malfunction of the automatic hook may prevent the execution of the manoeuvre controlled by the radio sensors (for example, the upward movement for the presence of wind). The manufacturer disclaims any liability due to improper use of radio sensors or other automatic control devices.

09.6.1 Logic operation of wind sensor

If the wind radio sensor measures a wind speed greater than the set threshold, the wind sensor sends the message of "wind alarm":motors tuned to it making an upward movement and inhibits the manual controls until the dangerous situation remains.

09.6.2 Logic operation of sun sensor

If the sun sensor measures a brightness above the set threshold for at least 2.5 minutes, the sensor sends the message "presence of sun" and the tuned motors make a lowering operation. If the sun sensor measures a brightness below the set threshold for at least 18 minutes, the sun sensor sends the message "absence of sun" and the tuned motors make an upward movement.

The "sun function" can be turned on / off from the transmitter (see transmitter manual "sun function"). If the "sun function" is inactive, the motor will ignore commands from the radio sensor about the sun sensor.

09.6.3 Logic operation of rain sensor

If the rain sensor measures a rainfall intensity above the set threshold, the rain sensor sends the message "presence of rain" and the tuned motor make a move up or down, depending on what you set on the rain sensor. The manual controls are still active. More rain sensors can be stored in the same motor.

09.7 ERROR SIGNAL

If the motor intercepts an abnormal operating condition (for example, a system error, the corruption of the information contained in the memory ...), the motor refuses to perform the manoeuvre commanded and indicates the fault with small movements. In this case you should consult a qualified technician to restore the proper functioning of the engine (see section 22, «Error signal and recovery operation").

10. MEMORIZATION / DELETION OF A RADIO DEVICE



For information about the modes of operation of radio sensors please refer to their instruction manuals and to Section 16 "Operating logic of radio sensors".

10.1 USING COMMAND BUTTONS

<p>A</p> <p>Bring the motor an the intermediate position.</p>	<p>B</p> <p>Switch OFF power supply, wait 2 seconds and switch ON power supply.</p>	<p>C ⁽¹⁾</p> <p>8 x DOWN</p> <p>Within 15 seconds press DOWN 8 times.</p>	<p>D</p> <p>The motor makes 3 small upward movements.</p>	<p>E ⁽²⁾</p> <p>3 x UP</p> <p>Within 15 seconds press UP 3 times.</p>						
<p>F</p> <p>The motor makes 2 small upward movements.</p>	<p>G WITHIN 15 SECONDS PRESS:</p> <table border="1"> <tr> <th data-bbox="304 763 596 1025">TRANSMITTER</th> <th data-bbox="624 763 916 1025">WIND SENSOR</th> <th data-bbox="943 763 1233 1025">RAIN SENSOR</th> </tr> <tr> <td data-bbox="304 763 596 1025"> <p>STOP</p> </td> <td data-bbox="624 763 916 1025"> <p>P1</p> </td> <td data-bbox="943 763 1233 1025"> <p>P2</p> </td> </tr> </table>			TRANSMITTER	WIND SENSOR	RAIN SENSOR	<p>STOP</p>	<p>P1</p>	<p>P2</p>	<p>H</p> <p>Memorized! Deleted!</p> <p>The motor signals the operation performed.</p>
TRANSMITTER	WIND SENSOR	RAIN SENSOR								
<p>STOP</p>	<p>P1</p>	<p>P2</p>								

Note:

- ✓ (1) : the button must be pressed briefly (less than 0.5 sec) and in rapid succession (max 1 seconds between each press and the next).
- ✓ (2) : the button must be pressed briefly (less than 0.5 sec) and in rapid succession (max 1 seconds between each press and the next).
- ✓ (3) Radio devices: Hold down the button on the transmitter or radio sensor until the motor performs the signal in point H. In particular, to memorize or delete a battery powered sensor you may need to hold the button up to 10 seconds. If the button is not pressed within 15 seconds, the motor exits the programming and signals it with 2 downward movements (upward for Orientable Roller Shutter).

10.2 USING AN HAND-HELD TRANSMITTER

<p>A</p> <p>Bring the motor in an intermediate position.</p>	<p>B</p> <p>Press and hold PROG of a transmitter already memorized for about 5 sec.</p>	<p>C</p> <p>The motor makes 2 small upward movements.</p>							
<p>D WITHIN 15 SECONDS PRESS:</p> <table border="1"> <tr> <th data-bbox="70 1697 362 1960">TRANSMITTER</th> <th data-bbox="389 1697 681 1960">WIND SENSOR</th> <th data-bbox="708 1697 1000 1960">RAIN SENSOR</th> </tr> <tr> <td data-bbox="70 1697 362 1960"> <p>STOP</p> </td> <td data-bbox="389 1697 681 1960"> <p>P1</p> </td> <td data-bbox="708 1697 1000 1960"> <p>P2</p> </td> </tr> </table>			TRANSMITTER	WIND SENSOR	RAIN SENSOR	<p>STOP</p>	<p>P1</p>	<p>P2</p>	<p>E</p> <p>Memorized! Deleted!</p> <p>The motor signals the operation performed.</p>
TRANSMITTER	WIND SENSOR	RAIN SENSOR							
<p>STOP</p>	<p>P1</p>	<p>P2</p>							

Note:

- ✓ (1) Radio device: Hold down the button on the transmitter or radio sensor until the motor performs the signal in point E. In particular, to memorize or delete a battery powered sensor you may need to hold the button up to 10 seconds. If the button is not pressed within 15 seconds, the motor exits the programming and signals it with 2 downward movements (upward for Orientable Roller Shutter).
- ✓ If the motor has memorized a single hand-held transmitter, it can't be deleted (the non-cancellation is indicated by two downward movements).

11. FINE ADJUSTMENT OF UPPER LIMIT SWITCH



The modification of the upper limit switch is not possible if the upper limit switch has been learned by contact with an obstacle

11.1 USING COMMAND BUTTONS

01. Bring the motor to the upper position
02. Switch off power supply and wait 2 seconds.
03. Supply the motor.
04. Within 15 sec, press briefly 8 times UP. The motor makes 3 small downward movements. (*)
05. Within 15 sec, press briefly 2 times DOWN. The motor makes 1 small upward movement. (*)
06. Within 10 sec, press the UP and DOWN buttons to fine-tune the limit switch (motor moves in small steps in the selected direction).
07. Wait without pressing any buttons. After 10 seconds, the motor makes 2 alternate movements (up / down) to signal that the new limit switch has been stored.

(*) the button must be pressed briefly (less than 0.5 sec) and in rapid succession (max 1 seconds between each press and the next)

11.2 USING AN HAND-HELD TRANSMITTER

01. Bring the motor to the upper position
02. Press in sequence the STOP, PROG, UP buttons. The motor makes 1 small downward movement. (*)
03. Press the UP and DOWN buttons to fine-tune the limit switch (motor moves in small steps in the selected direction).
04. Press PROG briefly. the motor makes 2 alternate movements (up / down) to signal that the new limit switch has been stored.

(*) the button must be pressed briefly and in rapid succession (max 2 seconds between each press and the next)

12. FINE ADJUSTMENT OF LOWER LIMIT SWITCH

12.1 USING COMMAND BUTTONS

01. Bring the motor to the lower position
02. Switch off power supply and wait 2 seconds.
03. Supply the motor.
04. Within 15 sec, press briefly 8 times DOWN. The motor makes 3 small upward movements. (*)
05. Within 15 sec, press briefly 2 times DOWN. The motor makes 1 small downward movement. (*)
06. Within 10 sec, press the UP and DOWN buttons to fine-tune the limit switch (motor moves in small steps in the selected direction).
07. Wait without pressing any buttons. After 10 seconds, the motor makes 2 alternate movements (up / down) to signal that the new limit switch has been stored.

(*) the button must be pressed briefly (less than 0.5 sec) and in rapid succession (max 1 seconds between each press and the next)

12.2 USING AN HAND-HELD TRANSMITTER

01. Bring the motor to the lower position
02. Press in sequence the STOP, PROG, DOWN buttons. The motor makes 1 small upward movement. (*)
03. Press the UP and DOWN buttons to fine-tune the limit switch (motor moves in small steps in the selected direction).
04. Press PROG briefly. The motor makes 2 alternate movements (up / down) to signal that the new limit switch has been stored.

(*) the button must be pressed briefly and in rapid succession (max 2 seconds between each press and the next)

13. MODIFY BOTH THE LIMIT SWITCHES



This operation can only be performed via an hand-held transmitter.
Before you do this, **make sure any manual hooks are disconnected.**

WARNING:

This procedure can change the limits even if not completed.
For this reason, in case of interruption of the procedure is necessary to repeat the same integrally.

01. Bring the motor in an intermediate position.
02. Press in sequence the STOP, PROG, STOP buttons. The motor makes 2 alternate movements (up / down). (*)
03. Wait... motor moves downward.
04. **Follow as described in Section 8, points H and subsequent.**

(*) the button must be pressed briefly and in rapid succession (max 2 seconds between each press and the next)

14. INTERMEDIATE LIMIT SWITCH

14.1 USING COMMAND BUTTONS

To memorize the intermediate limit switch:

01. Bring the motor in the preferred position.
02. Briefly press DOWN 6 times. The motor makes an alternate movement up / down to indicate that the position has been stored. (*)

To recall the intermediate limit switch:

01. Briefly press DOWN 2 times. (*)

(*) the button must be pressed briefly (less than 0.5 sec) and in rapid succession (max 1 seconds between each press and the next)

14.2 USING AN HAND-HELD TRANSMITTER

Depending on the transmitter, follow one of the procedures described in Sections 14.2.1 - 14.2.4. For more information, refer to the manual of the transmitter.

14.2.1 Procedure with «ARCO» series transmitter

To memorize the intermediate limit switch:

01. Bring the motor in the preferred position.
02. Press STOP and then FOR ME and hold the buttons until the motor signalation (about 5 seconds).

To recall the intermediate limit switch:

01. Press FOR ME

14.2.2 Procedure with «VISIO» series transmitter

To memorize the intermediate limit switch:

01. Bring the motor in the preferred position.
02. Press STOP and then ME and hold the buttons until the motor signalation (about 5 seconds)

To recall the intermediate limit switch:

01. Press ME

14.2.3 Procedure with «FLUTE» and «KUADRO» series transmitter

To memorize the intermediate limit switch:

01. Bring the motor in the preferred position.
02. Press STOP 6 TIMES and then press and hold the DOWN button for about 5 seconds. The motor makes an alternate movement up / down to indicate that the position has been stored. (*)

To recall the intermediate limit switch:

01. Press STOP 3 times (*)

(*) the button must be pressed briefly (less than 0.5 sec) and in rapid succession (max 1 seconds between each press and the next)

14.2.4 Procedure with «KILION» series transmitter

To memorize the intermediate limit switch:

01. Bring the motor in the preferred position.
02. Press SETUP-CHANNELS.
03. Select the channel associated with the motor.
04. Select «Command Set».
05. Press the WRITE-FOR ME button for about 5 seconds. The motor makes an alternate movement up / down to indicate that the position has been stored.

To recall the intermediate limit switch:

01. Press FOR ME

15. SUN, WIND and RAIN SENSOR

Advanced Info



The sensors generate automatic manoeuvres without notice which may be dangerous. The installer must inform the end user and, if necessary, integrate adequate security systems.

In some situations (eg loss of motor or sensor voltage, motor or sensor failure, radio noise...) it is possible that the command imparted by the sensor is not detected by the motor. The sensor must therefore not be understood as a safety device which ensures the integrity of the roller in every condition, but a means to limit the probability that the shutter could be damaged by adverse weather conditions.

15.1 COMPATIBLE SENSOR WITH KROG

The Krog motors have an integrated radio receiver and require the use of radio sensors. Use sensors BLAST or BLAST BT (wind sensor) or VEGA or VEGA BT (sun / wind sensor) or X11 (rain sensor) associated with AT12. The same sensor can be tuned to multiple motors (see section 10 "Save-erase a radio device"). When the sensor detects the presence of wind, a "wind alarm" message is sent and tuned motors move in upward direction and manual controls are disabled until the end of the alarm. When the sensor detects the presence of the sun, it sends a "presence of sun" message and the tuned motors move in downward direction. When the sensor detects the absence of the sun, a "sun absent" message is sent: the tuned motors move in upward direction. When the sensor detects the presence of rain, it sends the message "presence of rain": the tuned motors move in upward or downward direction depending on the rain sensor setup.

Each motor can store up to 4 wind sensors and only one sun sensor.

For connections and more information regarding the thresholds of wind or sun or rain, the timing of intervention and the operating logic of the sensors, please refer to the instruction manual of the sensors.

It's possible to choose whether the command buttons should work in IMPULSE logic or in HOLD TO RUN logic.

- ✓ IMPULSE logic: this is the default mode at the factory. The motor moves in upward or downward direction if the relative contact (wire gray or black) is closed on phase for at least 0.5 sec, the motor will stop if it is closed briefly (less than 0.5 sec) any of the two contacts.
- ✓ HOLD TO RUN logic: the motor moves in upward or downward direction if the relative contact (wire gray or black) is closed on phase for at least 0.5 sec, the motor stops as soon as the contact opens.

16.1 USING THE COMMAND BUTTONS

01. Bring the motor to the upper position.
02. Remove power and wait 2 seconds.
03. Supply the motor.
04. Within 15s , press briefly 8 times UP. The motor makes 3 small downward movements. (*)
05. Within 15s , press briefly 3 times UP. The motor makes 1 upward movement if the current setting is HOLD TO RUN, 1 downward movement if the current setting is IMPULSE. (*)
06. Within 15s press briefly UP to select HOLD TO RUN mode or press briefly DOWN to select IMPULSE mode. In order to not change the setting wait without pressing any button.
07. Wait without pressing any buttons. After a few seconds the motor signals the new setting.

(*) the button must be pressed briefly (less than 0.5 sec) and in rapid succession (max 1 seconds between each press and the next)

16.2 USING AN HAND-HELD TRANSMITTER

Depending on the transmitter, follow one of the procedures described in Sections 16.2.1 - 16.2.4. For more information, refer to the manual of the transmitter.

16.2.1 Procedure with «ARCO» series transmitter

01. Bring the motor in an intermediate position.
02. Press and hold for 5 seconds the MENU button until the display shows «rS» (receiver setups).
03. Press PREV 1 time and NEXT 8 times, the display shows «18».
04. Press STOP. The motor signals the current setting (upward=HOLD TO RUN, downward=IMPULSE).
05. Press PREV to select IMPULSE or press NEXT to select HOLD TO RUN.
06. Press STOP. The motor signals the new setting (upward=HOLD TO RUN, downward=IMPULSE).

16.2.2 Procedure with «VISIO» series transmitter

01. Bring the motor in an intermediate position.
02. Press MENU, the display shows «Menu Rx».
03. Press NEXT repeatedly until the display shows "18".
04. Press STOP. The motor signals the current setting (upward=HOLD TO RUN, downward=IMPULSE).
05. Press DOWN to select IMPULSE or press UP to select HOLD TO RUN.
06. Press STOP. The motor signals the new setting (upward=HOLD TO RUN, downward=IMPULSE).

16.2.3 Procedure with «FLUTE» and «KUADRO» series transmitter

01. Bring the motor in an intermediate position.
02. While pressing STOP press also PROG for about 1 second, until all the LEDs light up (KUADRO: the UP button lights up), then release the buttons.
03. Press Up 1 time and press DOWN 8 times. (*)
04. Press STOP. The motor signals the current setting (upward=HOLD TO RUN, downward=IMPULSE). (KUADRO: the DOWN button lights up)
05. Press DOWN to select IMPULSE or press UP to select HOLD TO RUN.
06. Press STOP. The motor signals the new setting (upward=HOLD TO RUN, downward=IMPULSE).

(*) the button must be pressed briefly (less than 0.5 sec) and in rapid succession (max 1 seconds between each press and the next)

16.2.4 Procedure with «KILION» series transmitter

01. Bring the motor in an intermediate position.
02. Press SETUP - CHANNELS.
03. Select the channel associated with the motor.
04. Select «Receiver Menu»
05. Select the menu 18 and confirm. The motor signals the current setting (upward=HOLD TO RUN, downward=IMPULSE).
06. Press OFF to select IMPULSE or press ON to select HOLD TO RUN. Then confirm.
07. The motor signals the new setting (upward=HOLD TO RUN, downward=IMPULSE).

As soon as the motor stores a wind radio sensor or a sun / wind radio sensor, automatically activates a communication control between the radio sensor and itself. If communication is lost for more than 60 minutes, the motor performs an upward movement to protect the blind. This manoeuvre is performed automatically every 60 minutes until the restoration of radio communication. The factory recommends to keep active the "radio test" in order to identify in good time any malfunction of the sensor radio.

17.1 USING THE COMMAND BUTTONS

01. Bring the motor to the upper position.
02. Remove power and wait 2 seconds.
03. Supply the motor.
04. Within 15s , press briefly 8 times UP. The motor makes 3 small downward movements. (*)
05. Within 15s , press briefly 5 times UP. The motor makes 1 upward movement if the function is ACTIVE, 1 downward movement if the function is INACTIVE. (*)
06. Within 15s press briefly UP to ACTIVATE the function or press briefly DOWN to INACTIVATE the . In order to not change the setting wait without pressing any button.
07. Wait without pressing any buttons. After a few seconds the motor signals the new setting.

(*) the button must be pressed briefly (less than 0.5 sec) and in rapid succession (max 1 seconds between each press and the next)

17.2 USING AN HAND-HELD TRANSMITTER

Depending on the transmitter, follow one of the procedures described in Sections 17.2.1 - 17.2.4. For more information, refer to the manual of the transmitter.

17.2.1 Procedure with «ARCO» series transmitter

01. Bring the motor in an intermediate position.
02. Press and hold for 5 seconds the MENU button until the display shows «rS» (receiver setups).
03. Press PREV 1 time and NEXT 7 times, the display shows «17».
04. Press STOP. The motor signals the current setting (upward=ACTIVE, downward=INACTIVE).
05. Press PREV to ACTIVATE the function or press NEXT to INACTIVATE the function.
06. Press STOP. The motor signals the new setting (upward=ACTIVE, downward=INACTIVE).

17.2.2 Procedure with «VISIO» series transmitter

01. Bring the motor in an intermediate position.
02. Press MENU, the display shows «Menu Rx».
03. Press NEXT repeatedly until the display shows "17".
04. Press STOP. The motor signals the current setting (upward=ACTIVE, downward=INACTIVE).
05. Press UP to ACTIVATE the function or press DOWN to INACTIVATE the function.
06. Press STOP. The motor signals the new setting (upward=ACTIVE, downward=INACTIVE).

17.2.3 Procedure with «FLUTE» and «KUADRO» series transmitter

01. Bring the motor in an intermediate position.
02. While pressing STOP press also PROG for about 1 second, until all the LEDs light up (KUADRO: the UP button lights up), then release the buttons.
03. Press Up 1 time and press DOWN 7 times. (*)
04. Press STOP. The motor signals the current setting (upward=ACTIVE, downward=INACTIVE).
(KUADRO: the DOWN button lights up)
05. Press UP to ACTIVATE the function or press DOWN to INACTIVATE the function.
06. Press STOP. The motor signals the new setting (upward=ACTIVE, downward=INACTIVE).

(*) the button must be pressed briefly (less than 0.5 sec) and in rapid succession (max 1 seconds between each press and the next)

17.2.4 Procedure with «KILION» series transmitter

01. Bring the motor in an intermediate position.
02. Press SETUP - CHANNELS.
03. Select the channel associated with the motor.
04. Select «Receiver Menu»
05. Select the menu 17 and confirm. The motor signals the current setting (upward=ACTIVE, downward=INACTIVE).
06. Press ON to ACTIVATE the function or press OFF to INACTIVATE the function. Then confirm.
07. The motor signals the new setting (upward=ACTIVE, downward=INACTIVE).

If this function is active, the motor is able to detect the presence of obstacles during the downward movements. If the motor detects an obstacle, the operation is stopped and the motor performs a wide upward movement to allow removal of the obstacle. The motor is able to detect obstacles that stop instantly the roller blind (ie such as to block firmly the operation); obstacles that block the roller shutter only partially might not be detected by the motor. The factory sets the parameter to level 2.



The motor is able to detect obstacles that stop instantly the roller blind (ie such as to block firmly the operation); obstacles that partially block the roller shutter might not be detected by the motor.

Necessary condition for the proper operation of this feature is the use of the offset adapter, properly installed (see section 05 "Installation of offset adapters"). There are various types of offset adapters. For more information contact your dealer.

Tab. 01 - Obstacle detection on downward

N. of movements	Setting
1	Inactive
2	Minimum sensitivity
3	Medium sensitivity
4	Maximim sensitivity

18.1 USING THE COMMAND BUTTONS

01. Bring the motor in an intermediate position.
02. Remove power and wait 2 seconds.
03. Supply the motor.
04. Within 15s , press briefly 8 times DOWN. The motor makes 3 small upward movements. (*)
05. Within 15s , press briefly 7 times UP. The motor signals the current setting (from 1 to 4 movements, see Tab. 01)
06. Within 15s press briefly UP the number of times equal to the desired setting (1 to 4). In order to not change the setting wait without pressing any button.
07. Wait without pressing any buttons. After a few seconds the motor signals the new setting (from 1 to 4 movements, see Tab. 01).

(*) the button must be pressed briefly (less than 0.5 sec) and in rapid succession (max 1 seconds between each press and the next)

18.2 USING AN HAND-HELD TRANSMITTER

Depending on the transmitter, follow one of the procedures described in Sections 18.2.1 - 18.2.4. For more information, refer to the manual of the transmitter.

18.2.1 Procedure with «ARCO» series transmitter

01. Bring the motor in an intermediate position.
02. Press and hold for 5 seconds the MENU button until the display shows «rS» (receiver setups).
03. Press PREV 1 time and NEXT 3 times, the display shows «13».
04. Press STOP. The motor signals the current setting (from 1 to 4 movements, see Tab. 01).
05. Press NEXT the number of times equal to the desired setting (1 to 4).
06. Press STOP. The motor signals the new setting (from 1 to 4 movements, see Tab. 01)

18.2.2 Procedure with «VISIO» series transmitter

01. Bring the motor in an intermediate position.
02. Press MENU, the display shows «Menu Rx».
03. Press NEXT repeatedly until the display shows "13".
04. Press STOP. The motor signals the current setting (from 1 to 4 movements, see Tab. 01)
05. Press UP the number of times equal to the desired setting (1 to 4).
06. Press STOP. The motor signals the new setting (from 1 to 4 movements, see Tab. 01)

18.2.3 Procedure with «FLUTE» and «KUADRO» series transmitter

01. Bring the motor in an intermediate position.
02. While pressing STOP press also PROG for about 1 second, until all the LEDs light up (KUADRO: the UP button lights up), then release the buttons.
03. Press UP 1 time and press DOWN 3 times. (*)
04. Press STOP. The motor signals the current setting (from 1 to 4 movements, see Tab. 01)
(KUADRO: the DOWN button lights up)
05. Press DOWN the number of times equal to the desired setting (1 to 4).
06. Press STOP. The motor signals the new setting (from 1 to 4 movements, see Tab. 01)

(*) the button must be pressed briefly (less than 0.5 sec) and in rapid succession (max 1 seconds between each press and the next)

18.2.4 Procedure with «KILION» series transmitter

01. Bring the motor in an intermediate position.
02. Press SETUP - CHANNELS.
03. Select the channel associated with the motor.
04. Select «Receiver Menu»
05. Select the menu 13 and confirm. The motor signals the current setting (from 1 to 4 movements, see Tab. 01).
06. Insert the desired setting (1 to 4). Then confirm.
07. The motor signals the new setting (from 1 to 4 movements, see Tab. 01)

During the rising phase, in the vicinity of the limit switches or in special situations, the motor may activate a torque reducer in such a way as to limit the force with which the motor goes to lean against the upper stop or to any hooks. During the learning phase of the stroke the motor calculates the optimal torque reduction. You can still increase (not reduce) the torque until at inhibiting the torque reducer. The factory sets the torque reducer at level 1 ("computed torque").



Level 1 ("computed torque") is the minimum torque that the motor has estimated to be sufficient for the movement of the roller blind. If the motor during normal operation does not have enough torque to move the roller blind, set this parameter to a higher level. A level 6 ("maximum torque") the torque reducer is disabled.

Tab. 02 - Traction in upper stop

N. of movements	Setting
1	Minimum traction
2	■ ■
3	■ ■ ■
4	■ ■ ■ ■
5	■ ■ ■ ■ ■
6	Maximum traction

19.1 USING THE COMMAND BUTTONS

01. Bring the motor in an intermediate position.
02. Remove power and wait 2 seconds.
03. Supply the motor.
04. Within 15s , press briefly 8 times DOWN. The motor makes 3 small upward movements. (*)
05. Within 15s , press briefly 4 times DOWN. The motor signals the current setting (from 1 to 6 movements, see Tab. 02)
06. Within 15s press briefly UP the number of times equal to the desired setting (1 to 6). In order to not change the setting wait without pressing any button.
07. Wait without pressing any buttons. After a few seconds the motor signals the new setting (from 1 to 6 movements, see Tab. 02).

(*) the button must be pressed briefly (less than 0.5 sec) and in rapid succession (max 1 seconds between each press and the next)

19.2 USING AN HAND-HELD TRANSMITTER

Depending on the transmitter, follow one of the procedures described in Sections 19.2.1 - 19.2.4. For more information, refer to the manual of the transmitter.

19.2.1 Procedure with «ARCO» series transmitter

01. Bring the motor in an intermediate position.
02. Press and hold for 5 seconds the MENU button until the display shows «rS» (receiver setups).
03. Press NEXT 9 times, the display shows «09».
04. Press STOP. The motor signals the current setting (from 1 to 6 movements, see Tab. 02).
05. Press NEXT the number of times equal to the desired setting (1 to 6).
06. Press STOP. The motor signals the new setting (from 1 to 6 movements, see Tab. 02)

19.2.2 Procedure with «VISIO» series transmitter

01. Bring the motor in an intermediate position.
02. Press MENU, the display shows «Menu Rx».
03. Press NEXT repeatedly until the display shows "09".
04. Press STOP. The motor signals the current setting (from 1 to 6 movements, see Tab. 02)
05. Press UP the number of times equal to the desired setting (1 to 6).
06. Press STOP. The motor signals the new setting (from 1 to 6 movements, see Tab. 02)

19.2.3 Procedure with «FLUTE» and «KUADRO» series transmitter

01. Bring the motor in an intermediate position.
02. While pressing STOP press also PROG for about 1 second, until all the LEDs light up (KUADRO: the UP button lights up), then release the buttons.
03. Press DOWN 9 times. (*)
04. Press STOP. The motor signals the current setting (from 1 to 6 movements, see Tab. 02)
(KUADRO: the DOWN button lights up)
05. Press DOWN the number of times equal to the desired setting (1 to 6).
06. Press STOP. The motor signals the new setting (from 1 to 6 movements, see Tab. 02)

(*) the button must be pressed briefly (less than 0.5 sec) and in rapid succession (max 1 seconds between each press and the next)

19.2.4 Procedure with «KILION» series transmitter

01. Bring the motor in an intermediate position.
02. Press SETUP - CHANNELS.
03. Select the channel associated with the motor.
04. Select «Receiver Menu»
05. Select the menu 09 and confirm. The motor signals the current setting (from 1 to 6 movements, see Tab. 02).
06. Insert the desired setting (1 to 6). Then confirm.
07. The motor signals the new setting (from 1 to 6 movements, see Tab. 02)

Allows you to set the force with which the terminal goes to lean on the hooks. You can choose from 4 levels of sensitivity (1 = minimum power, ..., 4 = maximum power). The factory sets the parameter at level 1. This parameter is not available if the motor has been programmed in "NO hooks" mode.



Level 1 ("minimum") is the minimum force that the motor has estimated to be sufficient to tense the fabric. If you want to increase the tension of the fabric, set this parameter to a higher level. At level 4 ("Maximum") the fabric is subjected to the maximum force.

Tab. 03 - Traction on hooks

N. of movements	Setting
1	Minimum
2	■ ■
3	■ ■ ■
4	Maximum

20.1 USING THE COMMAND BUTTONS

01. Bring the motor in an intermediate position.
02. Remove power and wait 2 seconds.
03. Supply the motor.
04. Within 15s , press briefly 8 times DOWN. The motor makes 3 small upward movements. (*)
05. Within 15s , press briefly 8 times DOWN. The motor signals the current setting (from 1 to 4 movements, see Tab. 03)
06. Within 15s press briefly UP the number of times equal to the desired setting (1 to 4). In order to not change the setting wait without pressing any button.
07. Wait without pressing any buttons. After a few seconds the motor signals the new setting (from 1 to 4 movements, see Tab. 03).

(*) the button must be pressed briefly (less than 0.5 sec) and in rapid succession (max 1 seconds between each press and the next)

20.2 USING AN HAND-HELD TRANSMITTER

Depending on the transmitter, follow one of the procedures described in Sections 20.2.1 - 20.2.4. For more information, refer to the manual of the transmitter.

20.2.1 Procedure with «ARCO» series transmitter

01. Bring the motor in an intermediate position.
02. Press and hold for 5 seconds the MENU button until the display shows «rS» (receiver setups).
03. Press PREV 1 time and press NEXT 4 times, the display shows «14».
04. Press STOP. The motor signals the current setting (from 1 to 4 movements, see Tab. 03).
05. Press NEXT the number of times equal to the desired setting (1 to 4).
06. Press STOP. The motor signals the new setting (from 1 to 4 movements, see Tab. 03)

20.2.2 Procedure with «VISIO» series transmitter

01. Bring the motor in an intermediate position.
02. Press MENU, the display shows «Menu Rx».
03. Press NEXT repeatedly until the display shows "14".
04. Press STOP. The motor signals the current setting (from 1 to 4 movements, see Tab. 03)
05. Press UP the number of times equal to the desired setting (1 to 4).
06. Press STOP. The motor signals the new setting (from 1 to 4 movements, see Tab. 03)

20.2.3 Procedure with «FLUTE» and «KUADRO» series transmitter

01. Bring the motor in an intermediate position.
02. While pressing STOP press also PROG for about 1 second, until all the LEDs light up (KUADRO: the UP button lights up), then release the buttons.
03. Press UP 1 time and press DOWN 4 times. (*)
04. Press STOP. The motor signals the current setting (from 1 to 4 movements, see Tab. 03)
(KUADRO: the DOWN button lights up)
05. Press DOWN the number of times equal to the desired setting (1 to 4).
06. Press STOP. The motor signals the new setting (from 1 to 4 movements, see Tab. 03)

(*) the button must be pressed briefly (less than 0.5 sec) and in rapid succession (max 1 seconds between each press and the next)

20.2.4 Procedure with «KILION» series transmitter

01. Bring the motor in an intermediate position.
02. Press SETUP - CHANNELS.
03. Select the channel associated with the motor.
04. Select «Receiver Menu»
05. Select the menu 14 and confirm. The motor signals the current setting (from 1 to 4 movements, see Tab. 03).
06. Insert the desired setting (1 to 4). Then confirm.
07. The motor signals the new setting (from 1 to 4 movements, see Tab. 03)

If the upper limit is stored for contact with an upper stop, you can decide whether the motor must always reach the upper stop (setting 1 "autozero no release"), if the motor must always reach the upper stop and drop the fabric briefly (setting 2 "autozero with release") or if the motor must stop a few cm before the upper stop and only occasionally (every 30 UP manoeuvres) to reach the stop (setting 3 "autozero with release every 30 UP manoeuvres"). In any case, each time the motor reaches the upper end position, the stroke is recalibrated in order to recover any shortening / lengthening of the fabric. The factory sets this parameter to 2 (autozero with release).

Tab. 04 - Autozero Mode

N. of movements	Setting
1	No release
2	With release
3	Release every 30 UP manoeuvres

21.1 USING THE COMMAND BUTTONS

01. Bring the motor in an intermediate position.
02. Remove power and wait 2 seconds.
03. Supply the motor.
04. Within 15s , press briefly 8 times DOWN. The motor makes 3 small upward movements. (*)
05. Within 15s , press briefly 5 times UP. The motor signals the current setting (from 1 to 3 movements, see Tab. 04)
06. Within 15s press briefly UP the number of times equal to the desired setting (1 to 3). In order to not change the setting wait without pressing any button.
07. Wait without pressing any buttons. After a few seconds the motor signals the new setting (from 1 to 3 movements, see Tab. 04).

(*) the button must be pressed briefly (less than 0.5 sec) and in rapid succession (max 1 seconds between each press and the next)

21.2 USING AN HAND-HELD TRANSMITTER

Depending on the transmitter, follow one of the procedures described in Sections 21.2.1 - 21.2.4. For more information, refer to the manual of the transmitter.

21.2.1 Procedure with «ARCO» series transmitter

01. Bring the motor in an intermediate position.
02. Press and hold for 5 seconds the MENU button until the display shows «rS» (receiver setups).
03. Press PREV 1 time and press NEXT 1 times, the display shows «11».
04. Press STOP. The motor signals the current setting (from 1 to 3 movements, see Tab. 04).
05. Press NEXT the number of times equal to the desired setting (1 to 3).
06. Press STOP. The motor signals the new setting (from 1 to 3 movements, see Tab. 04)

21.2.2 Procedure with «VISIO» series transmitter

01. Bring the motor in an intermediate position.
02. Press MENU, the display shows «Menu Rx».
03. Press NEXT repeatedly until the display shows "11".
04. Press STOP. The motor signals the current setting (from 1 to 3 movements, see Tab. 04)
05. Press UP the number of times equal to the desired setting (1 to 3).
06. Press STOP. The motor signals the new setting (from 1 to 3 movements, see Tab. 04)

21.2.3 Procedure with «FLUTE» and «KUADRO» series transmitter

01. Bring the motor in an intermediate position.
02. While pressing STOP press also PROG for about 1 second, until all the LEDs light up (KUADRO: the UP button lights up), then release the buttons.
03. Press UP 1 time and press DOWN 1 times. (*)
04. Press STOP. The motor signals the current setting (from 1 to 3 movements, see Tab. 04)
(KUADRO: the DOWN button lights up)
05. Press DOWN the number of times equal to the desired setting (1 to 3).
06. Press STOP. The motor signals the new setting (from 1 to 3 movements, see Tab. 04)

(*) the button must be pressed briefly (less than 0.5 sec) and in rapid succession (max 1 seconds between each press and the next)

21.2.4 Procedure with «KILION» series transmitter

01. Bring the motor in an intermediate position.
02. Press SETUP - CHANNELS.
03. Select the channel associated with the motor.
04. Select «Receiver Menu»
05. Select the menu 11 and confirm. The motor signals the current setting (from 1 to 3 movements, see Tab. 04).
06. Insert the desired setting (1 to 3). Then confirm.
07. The motor signals the new setting (from 1 to 3 movements, see Tab. 04)

If the motor intercepts an abnormal operating condition (such as a system error, the corruption of the information contained in memory, ...), the motor refuses to perform the manoeuvre commanded and signals the anomaly with 1 downward movement and 1 upward movement, repeated 3 times.

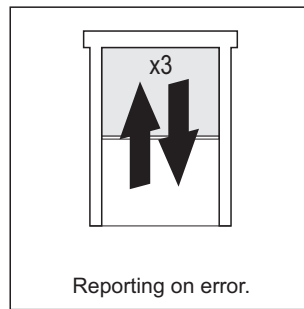

If the upper limit switch is NOT stored for contact with an upper stop, to restore the factory conditions is necessary to reset the motor (see section 23).

If the upper limit switch has been stored for contact with an upper stop, you can manually restore the functionality of the motor, without having to reset it. The restore operation is only possible using a memorized transmitter.

The operation of self-restore can be performed even if the motor does not report anomalies, and always under the supervision of a qualified technician. If the motor fails to complete the recovery manoeuvre (that is, independently reach the upper stop, see procedure below) it is possible that the motor failure is serious. In this case it is necessary a revision of the motor by the manufacturer.



This procedure can be performed only if the upper limit switch has been programmed for contact with an upper stop. Otherwise, the motor does not allow you to perform the recovery process.

This procedure should be done only under the supervision of a qualified technician.

The technician is responsible to verify that the motor stops in contact with the upper stop. Otherwise, it is obligatory to repeat the entire procedure.

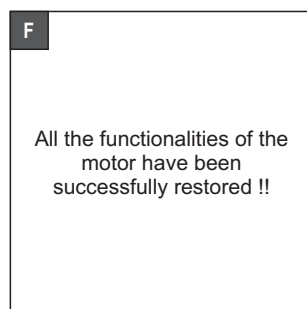
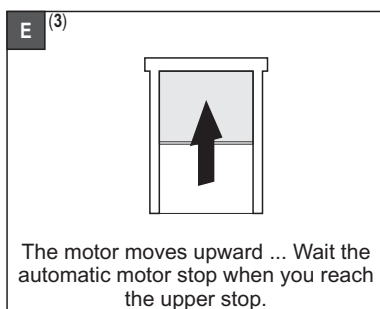
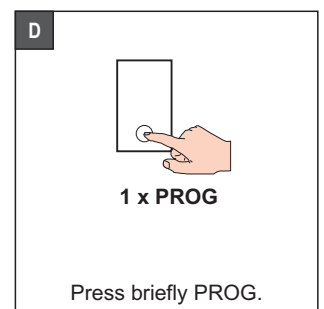
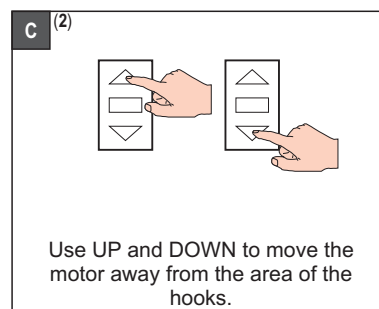
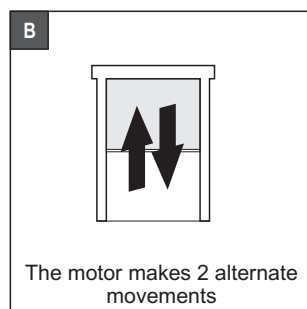
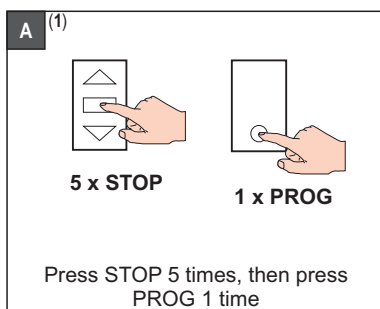



Notes:

- ✓ (1) : the button must be pressed about 1 second, wait about 1 second between each press and the next
- ✓ (2) : motor is in HOLD TO RUN mode
- ✓ (3) : if the motor stops in a different position from the upper stop is necessary to repeat fully the procedure.

23. RESET

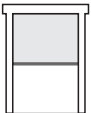
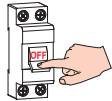
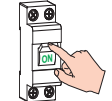
23.1 USING THE COMMAND BUTTONS

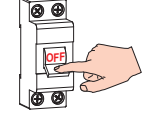
<p>A</p>  <p>If possible, bring the motor in an intermediate position</p>	<p>B</p>  <p>Switch off the power supply</p>	<p>C</p> <p style="text-align: center;">See scheme 1</p> <p>Connect as in scheme 1</p>	<p>D</p>  <p>Switch on power supply</p>	<p>E ⁽¹⁾</p>  <p>Wait 15 s, the motor makes a signaling</p>
<p>The transmitters codes and the radio sensors codes have been deleted!</p> <p>If you want to cancel the limit switches also continue, otherwise skip to step H.</p>	<p>F</p>  <p>Wait 15 s, the motor makes a signaling</p>	<p>G</p> <p style="text-align: center;">DONE!</p> <p>All conditions of the factory have been restored</p>	<p>H</p>  <p>Switch off the power supply</p>	<p>I</p> <p style="text-align: center;">See scheme2</p> <p>Restore the electrical connections</p>

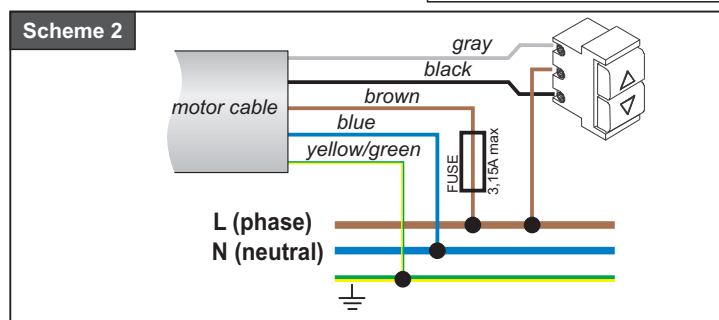
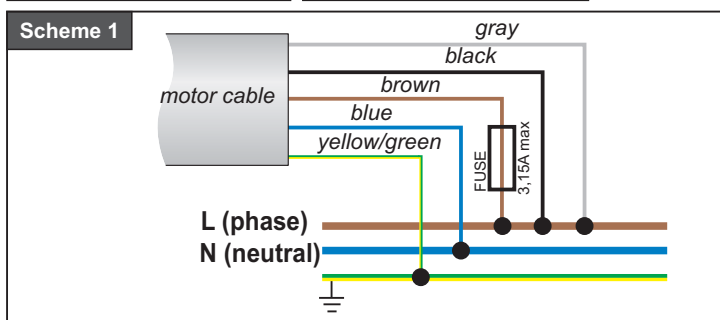

Note:

- ✓ (1) : in some cases signaling could not be made or carried out partially.

23.2 USING AN HAND-HELD TRANSMITTER

Depending on the transmitter, follow one of the procedures described in Sections 23.2.1 - 23.2.4. For more information, refer to the manual of the transmitter.

23.2.1 Procedure with «ARCO» series transmitter

01. If possible, bring the motor in an intermediate position.
02. Press and hold for 5 seconds the MENU button until the display shows «rS» (receiver setups).
03. Press PREV 2 time and press NEXT 9 times, the display shows «29».
04. Press STOP. The display flashes and the motor makes some movements (up/down 4 times alternate).
05. Wait the end of the movements.
06. Press together PREV and NEXT for about two seconds until the motor signals that the reset was performed (up / down 1 time).
07. Switch off the power supply.

23.2.2 Procedure with «VISIO» series transmitter

01. If possible, bring the motor in an intermediate position.
02. Press MENU, the display shows «Menu Rx».
03. Press NEXT repeatedly until the display shows "29".
04. Press STOP. The motor makes some movements (up/down 4 times alternate).
05. Wait the end of the movements.
06. Press together PREV and NEXT for about two seconds until the motor signals that the reset was performed (up / down 1 time).
07. Switch off the power supply.

23.2.3 Procedure with «FLUTE» and «KUADRO» series transmitter

01. If possible, bring the motor in an intermediate position.
02. While pressing STOP press also PROG for about 1 second, until all the LEDs light up (KUADRO: the UP button lights up), then release the buttons.
03. Press UP 2 times and press DOWN 9 times. (*)
04. Press STOP. The LEDs flashes and the motor makes some movements (up/down 4 times alternate).
05. Wait the end of the movements.
06. Press together UP and DOWN for about two seconds until the motor signals that the reset was performed (up / down 1 time).
07. Switch off the power supply.

(*) the button must be pressed briefly (less than 0.5 sec) and in rapid succession (max 1 seconds between each press and the next)

23.2.4 Procedure with «KILION» series transmitter

01. If possible, bring the motor in an intermediate position.
02. Press SETUP - CHANNELS.
03. Select the channel associated with the motor.
04. Select «Receiver Menu»
05. Select the menu 29 and confirm. The motor makes some movements (up/down 4 times alternate)
06. Confirm the operation. The motor signals that the reset was performed (up / down 1 time).
07. Switch off the power supply.

Corradi

OUTDOOR LIVING SPACE

All products and technical specifications given in this document are subject to variation without notice.

Unless previously and specifically authorised by the manufacturer, the device must be used exclusively with transmitters produced by the same manufacturer.

The manufacturer shall not be liable for damage resulting from improper, incorrect or unreasonable use. The producer declares that the device complies with the fundamental requirements and other provisions of Directive 1999/5/EC.

