



**Corradi**

OUTDOOR LIVING SPACE

**ALBA**

**Assembly  
instructions | EN**

rev. 1 / 09.2017

## Index

<a href="#">1. Important safety and assembly instructions</a>	<a href="#">2</a>
<a href="#">2. Dimensions</a>	<a href="#">2</a>
<a href="#">3. Construction types &amp; construction situations</a>	<a href="#">3</a>
<a href="#">4. Position motor, water drainage &amp; switch</a>	<a href="#">4</a>
<a href="#">5. Exploded view</a>	<a href="#">4</a>
<a href="#">6. Installation</a>	<a href="#">5</a>
<a href="#">7. Final check</a>	<a href="#">22</a>
<a href="#">8. Installation Lights</a>	<a href="#">23</a>

## 1 Important safety and assembly instructions

- Assembly recommended with at least two people and assembly lift.
- To avoid damage, check all mounting walls for gas, water and electrical conduits.
- Keep children, pets and unauthorized persons out of the area.
- Make sure no person or obstacle can obstruct a moving blade.
- Do not insert fingers or hands between the blades.
- Faulty installation or irregularities during installation can have serious consequences when the product is used.
- Only use the parts delivered by CORRADI or the guarantee conditions will no longer apply.
- Wall/floor or partition fasteners are not supplied. These should be chosen by the installer as they depend on the type of base material.
- Work carefully and always wear the necessary protective clothing.
- See also our CE booklet of operating and maintenance instructions. Give this booklet to your customer after installation.

## 2 Dimensions

Take following dimensions into account during installation:

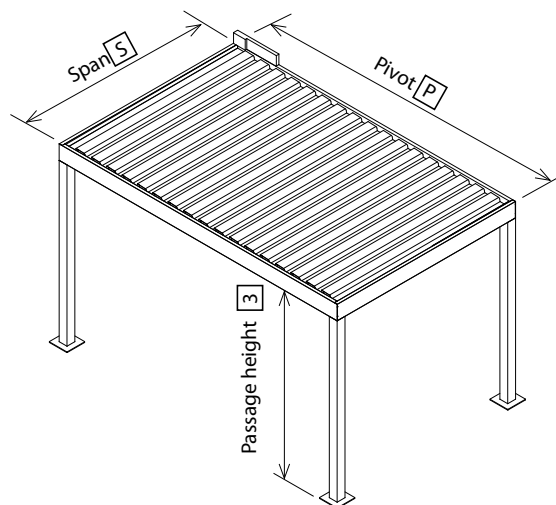

### 3 Construction types & construction situations

Below you can find a summary of the possible construction situations and construction types of Alba

Motor left

Motor right

Construction type 1: Stand-alone

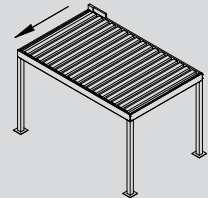
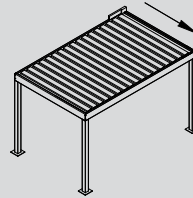
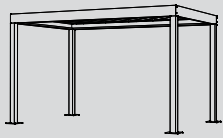

Construction situation 1:  
Wall // Span

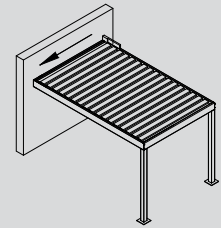
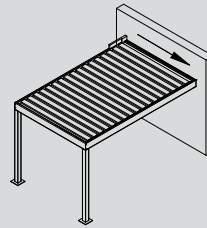

Type d'installation 2:  
Wall mounting

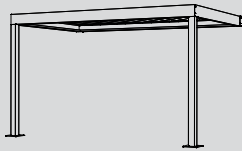

Construction situation 2:  
Wall // Pivot

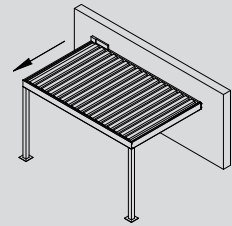
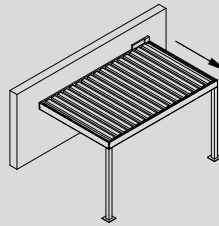

Construction situation 3:  
Wall // Span  
& Wall // Pivot

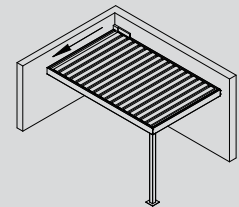
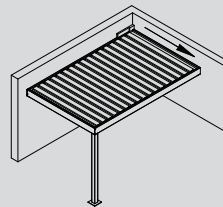

Construction type 3:  
Integration

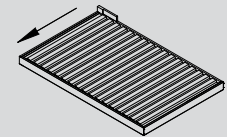
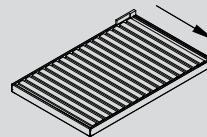
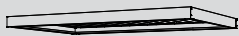

Construction type 4:  
Fitted on an open construction (No mounting holes)

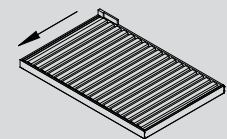
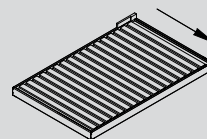

#### 4 Position motor, waterdrainage & switch

Take the position of the motor, water drainage and switch into account while installing the Alba.  
Check the position indicated on the order form.

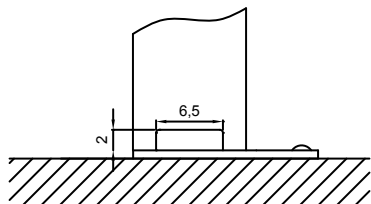

Position water drainage

#### 5 Exploded view

- ① Column
- ② Bracket
- ③ Motor
- ④ Blade
- ⑤ Driving profile
- ⑥ Housing Motor
- ⑦ Frame profile Span
- ⑧ Frame profile Pivot
- ⑨ Frame profile Pivot
- ⑩ Frame profile Span

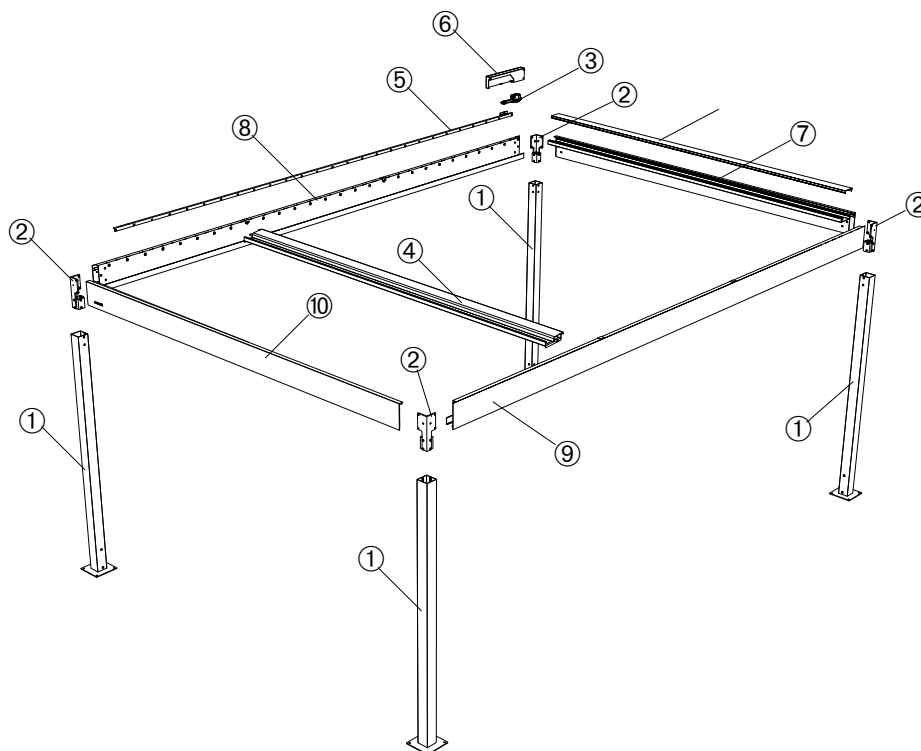

## 6 Installation

### 6.1 Installation basic construction (Columns + frame)

#### Step 1: Preparation mounting base & columns

1. Provide a hole at the underside of the mounting base ① to pass through the cable in case it needs to be concealed under the ground (**DETAIL A**).
2. Install the brackets ② to secure the frame on top of the columns ③ with screws DIN 7991 M8x16 (**DETAIL B** and **C**).
3. In case of construction type 2 & 3, special brackets are provided. They will be installed later (see step 5 variant).

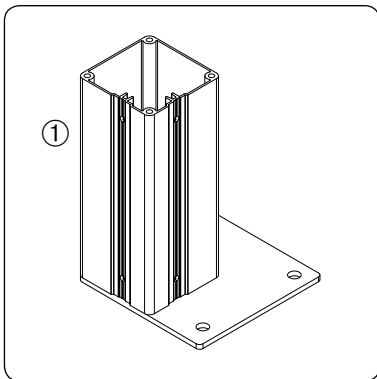
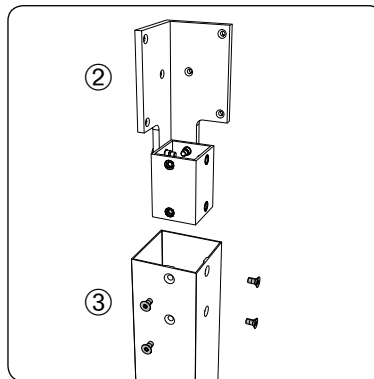
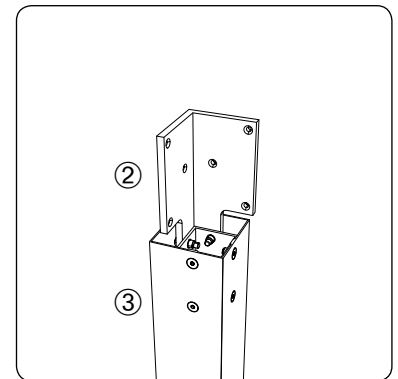
**DETAIL A**

**DETAIL B**

**DETAIL C**

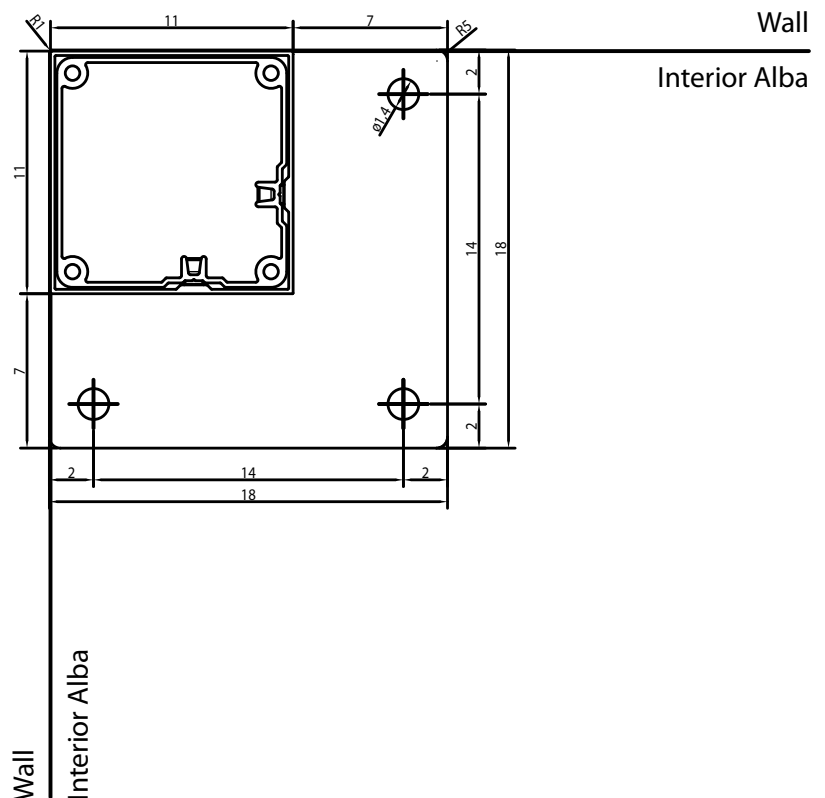
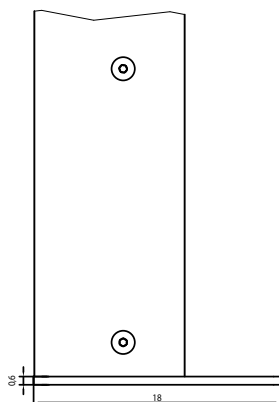
### Mounting base

Visible mounting base (X4)  
(against a construction - corner)



**Step 2: Determining the position of the assembly feet**

1. Mark off the plumb lines, the Pivot & Span of the Alba (laser, chalk line).
2. Mark off where the assembly feet will be fitted. Provide a stable surface under the assembly feet.
3. Place the mounting bases on their position. Point the angle of the bracket ① inwards. (**DETAIL A**).
4. Fix 1 mounting base with four screws. The other mounting base will be fixed later.

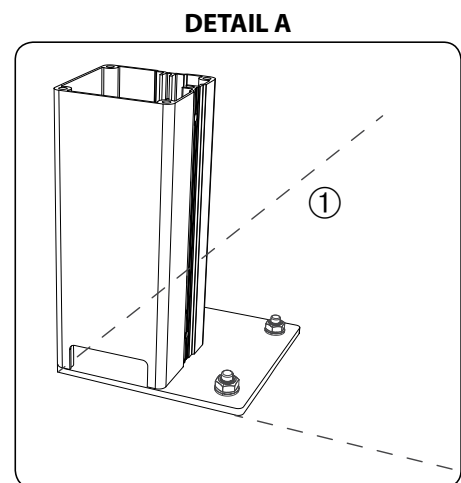
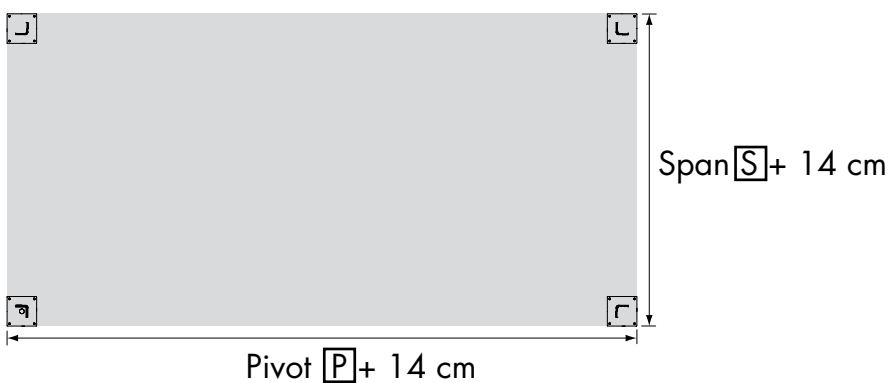
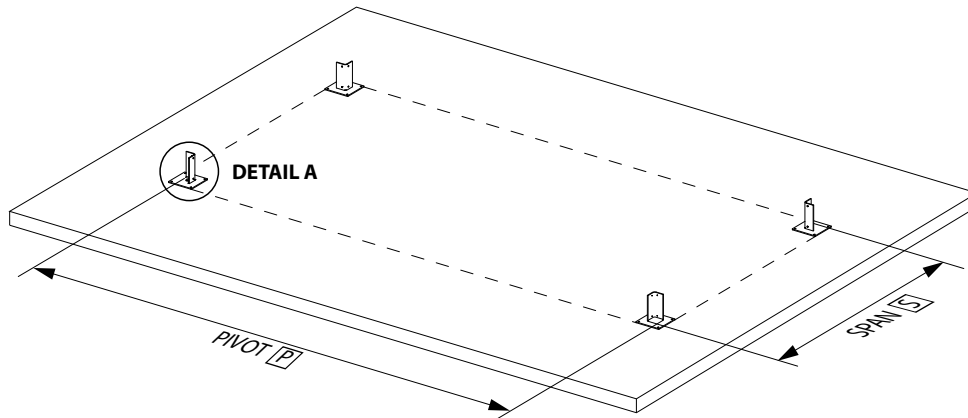
**Step 2 variant 1: Determining the position and fixing the assembly feet for construction type 2**

1. Mark off the plumb lines (laser, chalk line) in the height with respect to the reference zero level for the positioning of the frame profiles that will be mounted on the wall.
2. Position the frame profiles that will be mounted on the wall-side. Mark off the drill holes of the frame profiles and then remove the frame profiles. The grooves provided can help when determining the position of the drill holes.
3. Mark off the plumb lines of the Span and Pivot (laser, chalk line). Check the perpendicularity with respect to the reference zero level.
4. Mark off where the assembly foot/feet will be positioned in function of the type of construction situation. Provide a stable surface under the assembly feet.
5. Place the assembly feet in their positions. When doing so, point the angle of the bracket inwards.

**Step 3: Placing the columns**

1. Place the columns on the mounting bases with the angle of the bracket ① pointed outwards (**DETAIL A**).  
**Caution:** Check in which direction the water drainage holes need to be fitted (**DETAIL B**).
2. Secure each column to the mounting base with screws DIN7991 M8x16 (**DETAIL C**).

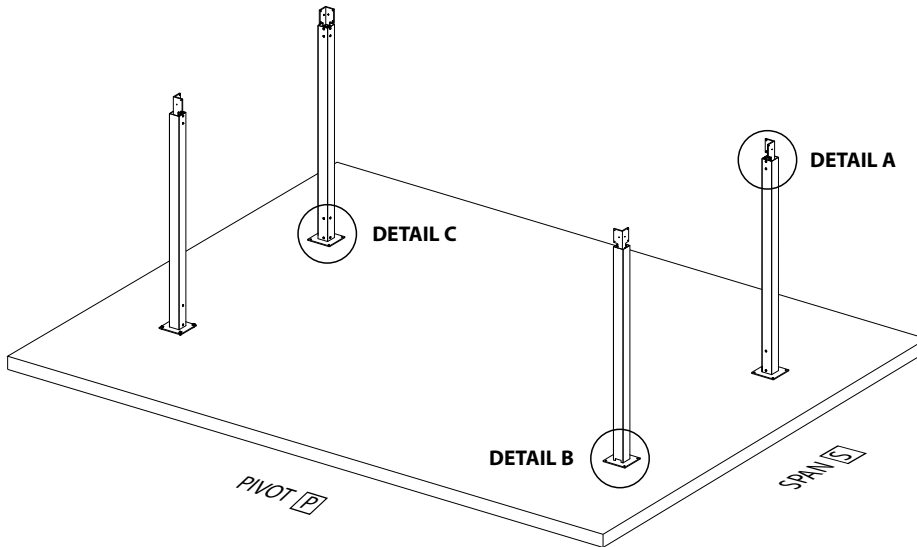
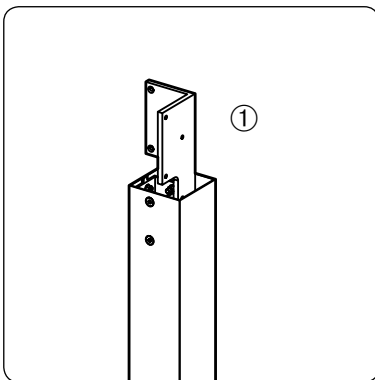
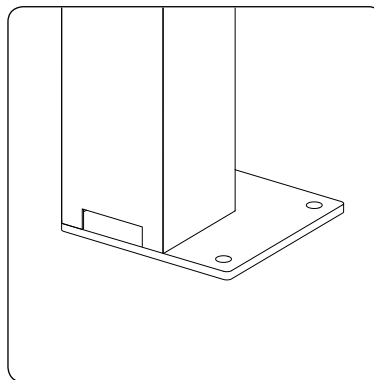
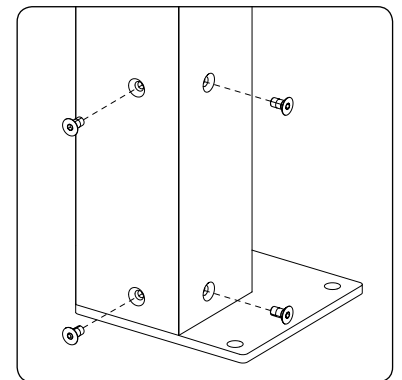
**DETAIL A****DETAIL B****DETAIL C**

**Step 4:** Positioning frame profiles + installation cables

1. Position the frame profiles on the ground.

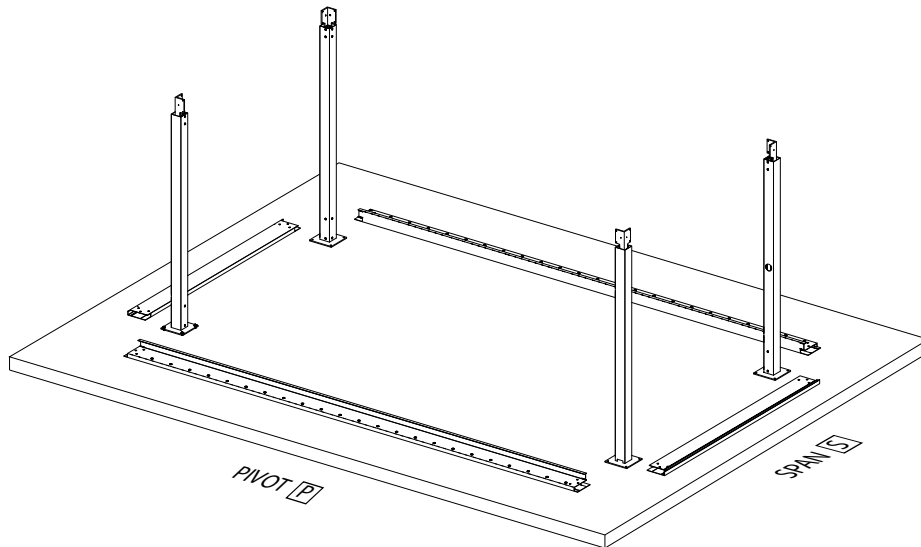
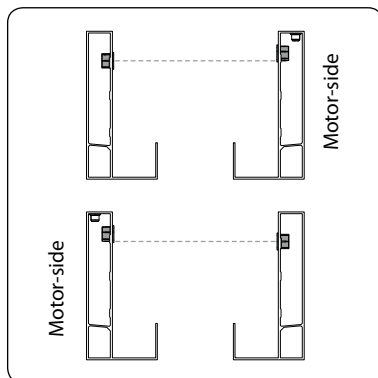
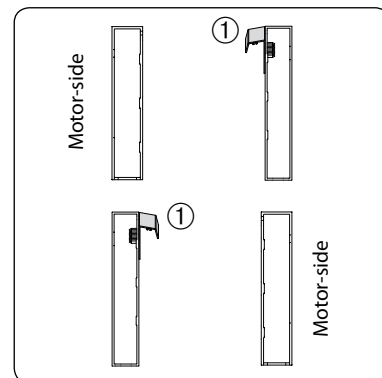
**Frame profile Pivot****Frame profile Span**

Profile with drill holes over its full length → **Pivot side**

**Caution:** Profile with the motor on top must be placed at the motor-side.

Other profiles → **Span side**

**Caution:** Profile that is provided with holes for the finishing profile, must be placed at the motor-side.

Profile that contains a sealing profile ① must be placed at the other side.

**Step 4: Positioning frame profiles + installation cables**

1. Check where the motor will be placed.  
Pass the cables through the cut-away for cable transmission (**DETAIL A & B**).
2. Secure the motor onto the bracket on the frame. Nuts pointed outwards (**DETAIL C**).
3. Open the general control box.
4. Open the rubber sealing (**DETAIL D**), connect the motor cable onto the 'output S1' (**DETAIL E**), and place the connector on 'S1'.  
The yellow cable need to be connected to 'S1-' and the green cable onto 'S1+'.

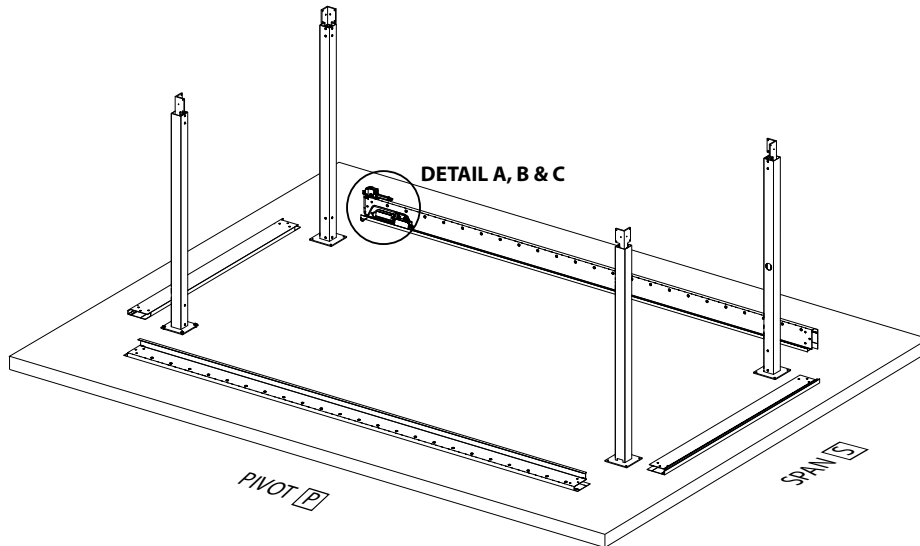
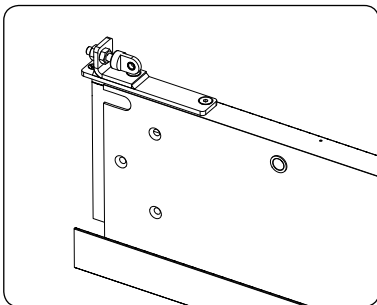
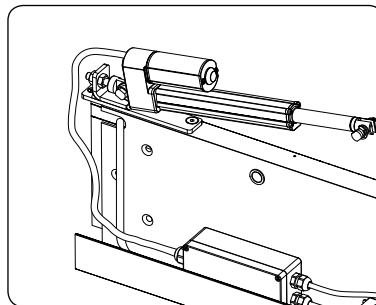
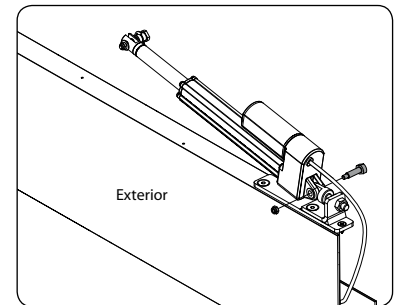
**DETAIL A****DETAIL B****DETAIL C**

Cut-away for cable transmission

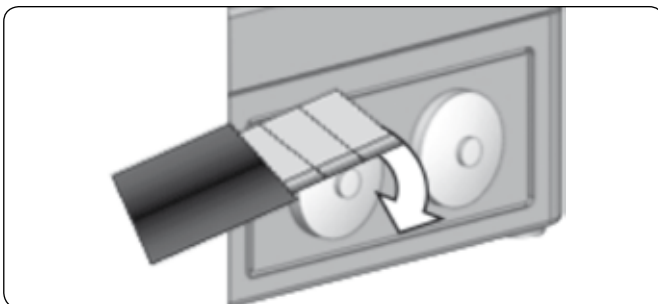
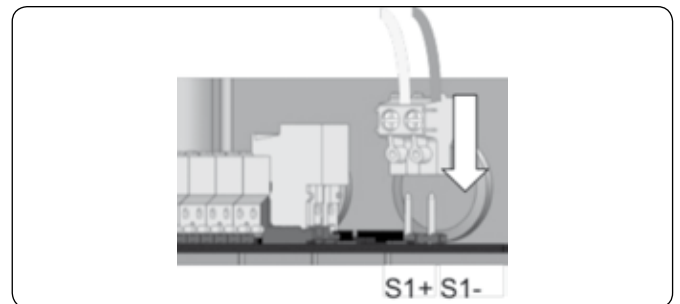
**DETAIL D****DETAIL E**

**Step 4 variant 1: Positioning frame profiles + installation cables with construction type 3**

1. Mark off the plumb lines (laser, chalk line) for the positioning of the frame profiles.
2. Position the frame profiles in the opening. Mark off the drill holes of the frame profiles and then remove the frame profiles.  
The grooves provided can help when determining the position of the drill holes.
3. Continue with Step 4 "Position frame profiles + installation cables", point 1 & 2.

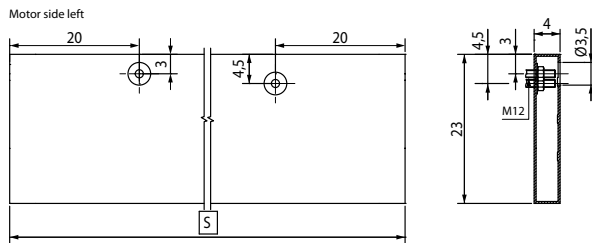
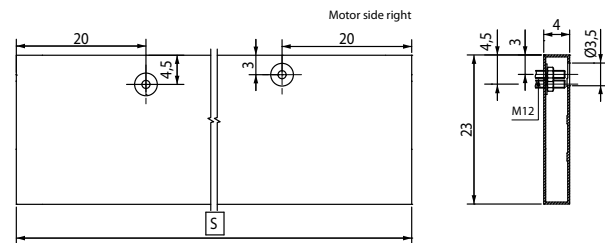
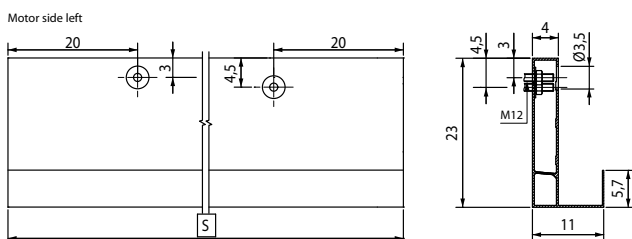
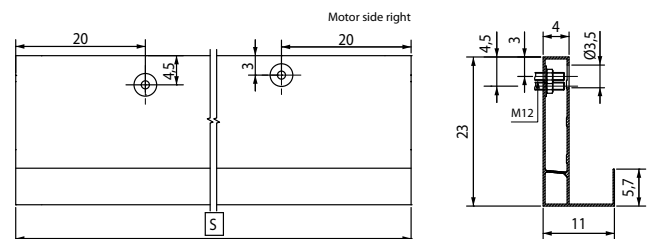
**Span****Frame profil up to 450 cm****Frame profil up to 450 cm****Frame profil, with gutter, up to 450 cm****Frame profil, with gutter, up to 450 cm**

**Pivot**

**Frame profil, with gutter, up to 390 cm**

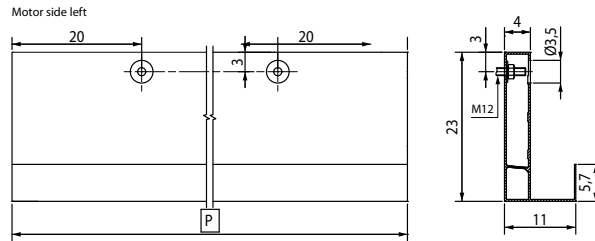

**Frame profil, with gutter, from 411,5 cm up to 497,5 cm**

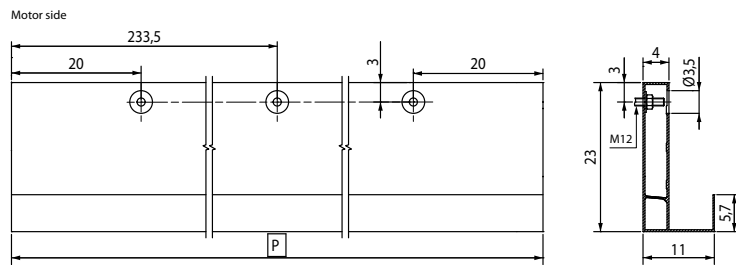

**Frame profil, with gutter, from 519 cm up to 605 cm**

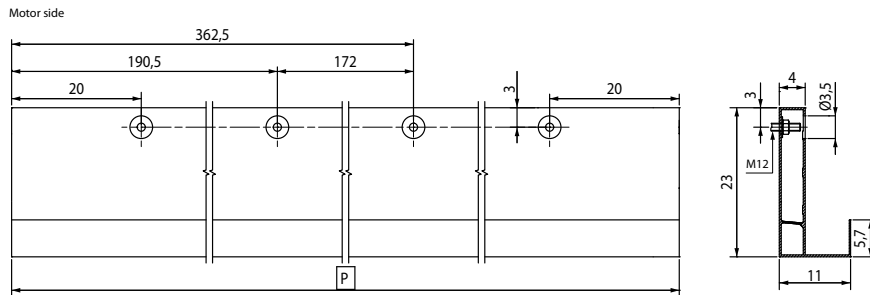

**Step 5: Installation frame**

1. Pass the cable, during installation, through the frame profiles until it reaches the proper column.  
Pass the cable downwards through the column.

**Caution:** If the cable needs to reach the diagonal opposite column, it needs to pass through the Pivot frame profile at the motor side (**DETAIL A**).

2. Check the position of the columns and install the frame profiles at the pivot-sides. Secure at both sides with screws DIN7991 M8x16 (**DETAIL B**).

3. Install the frame profiles at the span-side and secure at both sides with screws DIN7991 M8x16 (**DETAIL C**).

**Caution:** First install the Span frame profile at the side of the mounting base that is fixed (**DETAIL C**).

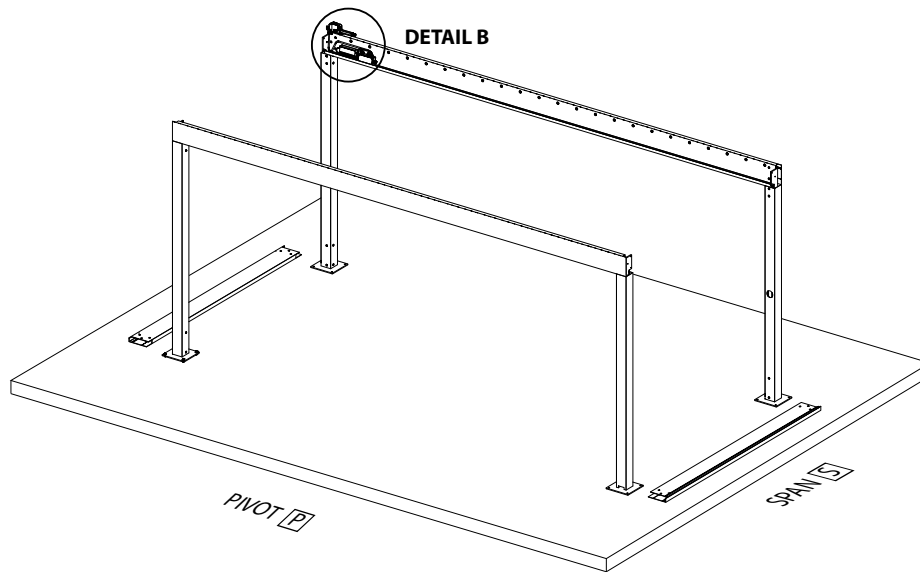
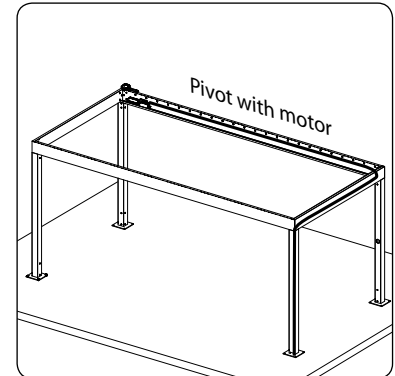
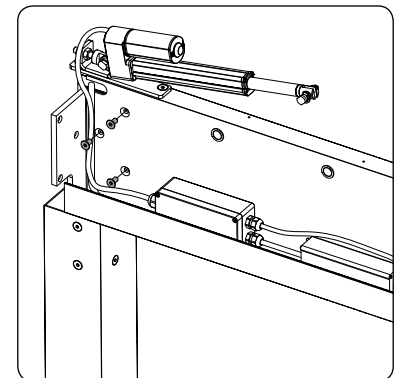
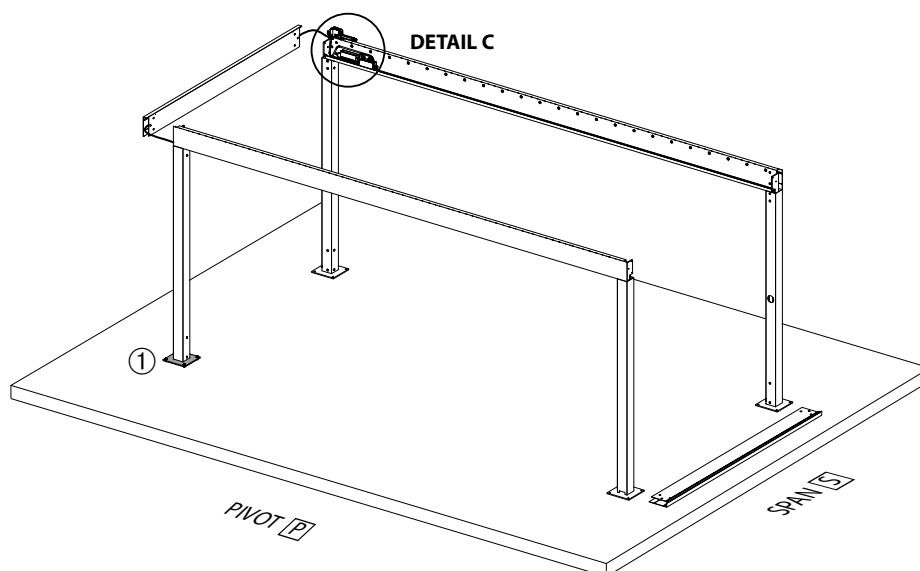
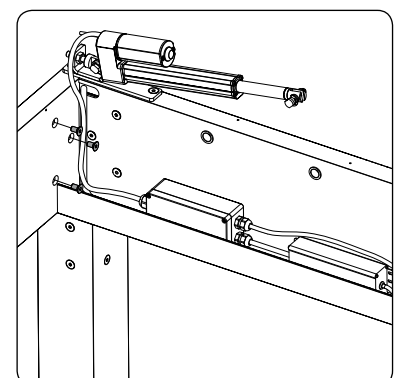
**Pivot frame profiles****DETAIL A****DETAIL B****Span frame profiles****DETAIL C**

### Step 5 variant: Installation of frame construction type 2, construction situations 1, 2 & 3

1. Mount the mounting brackets on the sides of the frame profiles which are equipped with drill holes for wall mounting. Secure these with screws DIN7991 M8x16.  
**Caution:** For construction situation 3, the brackets are mounted as follows:
    1. On both sides of the frame profile for the Span-side which must be attached to the wall.
    2. On one side of the frame profile for the Pivot-side which must be attached to the wall.  
**Caution:** Secure the bracket to the side that is not connected to the wall profile for the Span-side.
  2. Mount the frame profiles which must be attached to a wall. Provide the rear of the wall section with expansion tape. Before mounting, make sure that the wall is flat; if not, plaster the wall accordingly.  
**Caution:** For construction situation 3, first install the wall profile on the Span-side and then the wall profile on the Pivot-side.
  3. Secure to the wall with anchoring M12. Spray silicone\* in the upper groove between wall and wall section.  
**Caution:** Make sure that all of the corners are connected using a bracket and secure these with screws DIN7991 M8x16.
  4. Mount the other frame profiles. Secure these to the brackets with screws DIN7991 M8x16.  
**Caution:** Depending on the construction situation, these are mounted in a different sequence:
 

**Construction situation 1:**

    1. Frame profile Span-side between columns
    2. Frame profiles Pivot-sides between wall and column

**Construction situation 2:**

    1. Frame profile Pivot-side between columns
    2. Frame profiles Span-sides between wall and column

**Construction situation 3:**

    1. Frame profile Span-side between wall and column
    2. Frame profile Pivot-side between wall and column
  5. For construction situations 2 & 3, finish off the corner joints of the gutters where there is no column using an aluminium corner piece. Seal to ensure water-resistance using silicone.\*
- \* Use appropriate silicone in case of Texture coating (es. X-treme).

### Step 5 variant : Installation of frame construction type 3

1. Mount the mounting brackets on the sides of both frame profiles for the Span-side. Secure these with screws DIN7991 M8x16.
  2. Mount the frame profiles that must be attached to the wall. Provide the rear of the wall section with expansion tape. Before mounting, make sure that the wall is flat; if not, plaster the wall accordingly.  
**Caution:** First install the wall profiles on the Span-side and then the wall profiles on the Pivot-side.
  3. Secure to the wall with anchoring M12. Spray silicone\* in the upper groove between wall and wall section.  
**Caution:** Make sure that all of the corners are connected using a bracket and secure these with screws DIN7991 M8x16.
- \* Use appropriate silicone in case of texture coating (es. X-treme).

### Step 5 variant: Installation of frame construction type 4

1. Mount the brackets on the sides of both frame profiles for the Span-side. Secure these with screws DIN 7991 M8x16.
  2. Mount the frame profiles for the Pivot-side on the frame profiles for the Span-side using a bracket. Secure these with screws Din 7991 M8x16.  
**Caution:** Make sure that all of the corners are connected using a bracket.
  3. Finish off the corner joints of the gutters using an aluminium corner piece. Seal to ensure water-resistance using silicone.\*
  4. Install the frame of Alba on a support structure. Fixing should be provided by the installer.
- \* Use appropriate silicone in case of texture coating (es. X-treme).

**Step 6: Control**

1. Check the diagonals ( $D1 = D2$ ) and the distance between the columns. Make sure the columns form an angle of  $90^\circ$  with the frame. Make sure the corners of the frame form an angle of  $90^\circ$ .
2. Secure the mounting bases onto the floor.

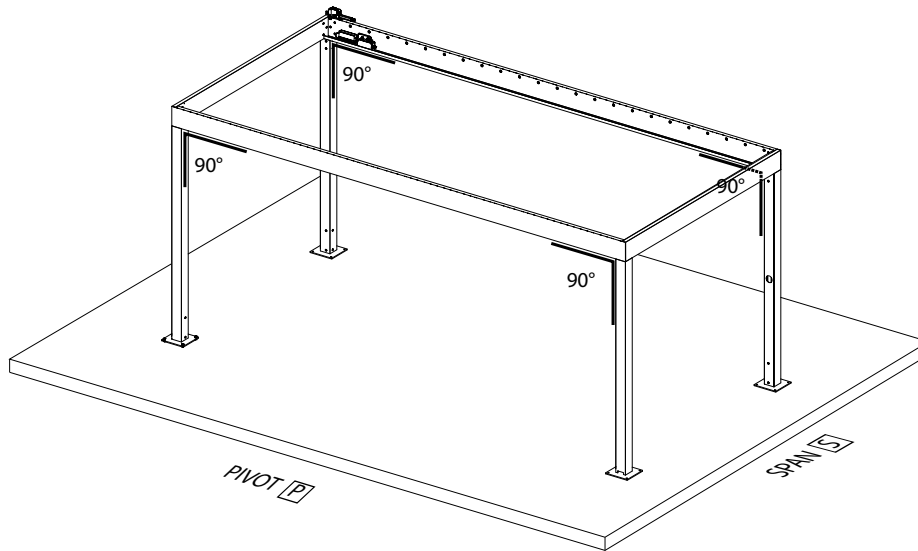
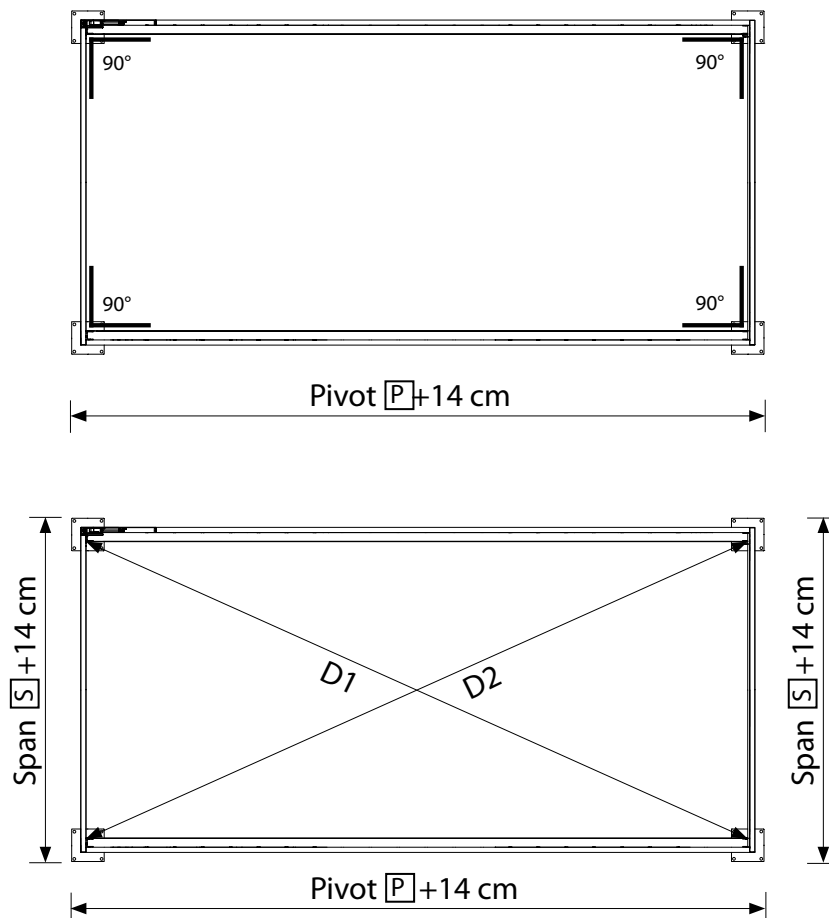
**Top view**

## 6.2 Installation blades & automation

### Step 1: Installation finishing profile

1. Install the finishing profile ① at the Span side where the motor will be installed. Secure to the frame with screws DIN7981 3,5 x 16 (**DETAIL A**).
2. Put the control box and the transformer into the finishing profile (**DETAIL B**).

#### Option - Lineo LED

1. Put the control box and the transformer into the finishing profile (**DETAIL B**).
2. Connect the cables (see manual 'Automation Alba')

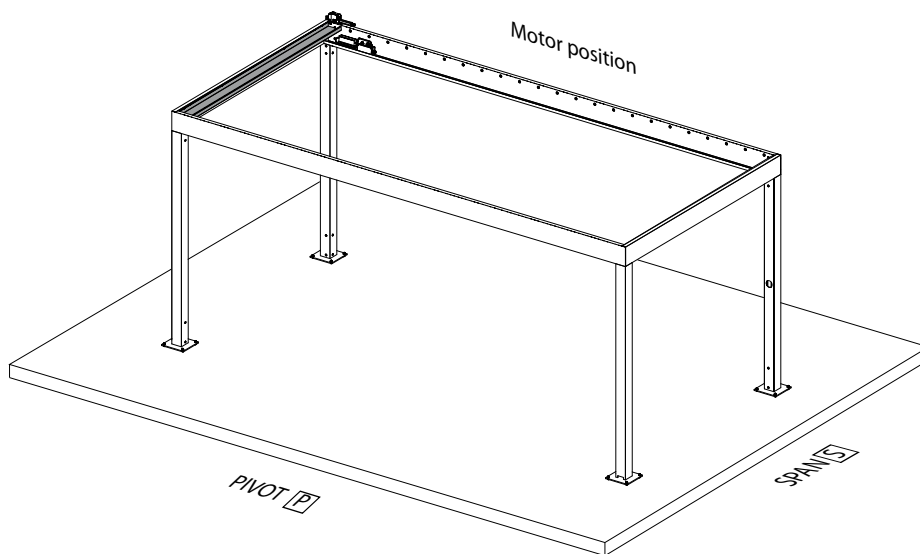

**DETAIL A**

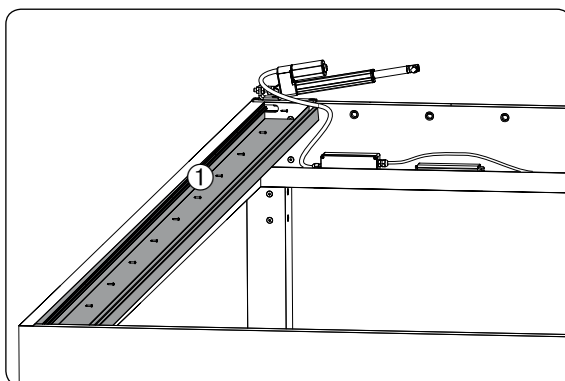

**DETAIL B**

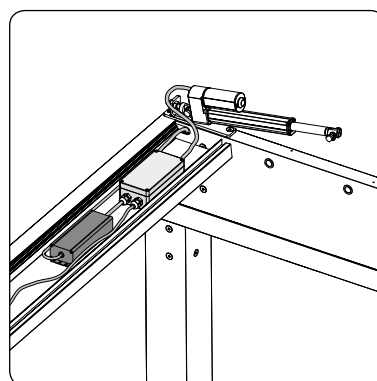

**Step 2: Installation blades**

1. Install the 2 outer blades in the frame. Check the orientation of the blade.

- Blade with 1 pin = Bearing side
- Blade with 2 pins (big pin ① and small pin ②) = Motor-side (**DETAIL A**).

2. Turn over the blade, slide the pin as far as possible into the provided hole in the frame at the bearing side ①. Hold the blade horizontal ② and slide the pin at the other side in the opposite frame profile ③. Secure the blade with a clips at the pin at the bearing side ③ (**DETAIL B**).

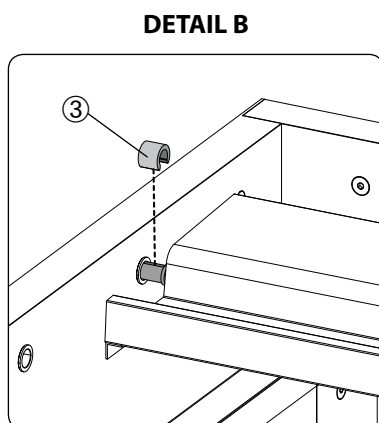
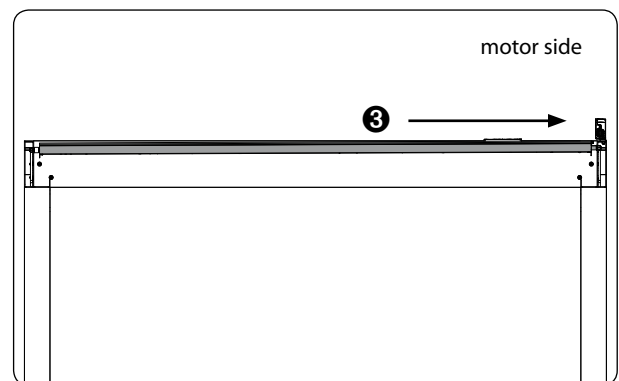
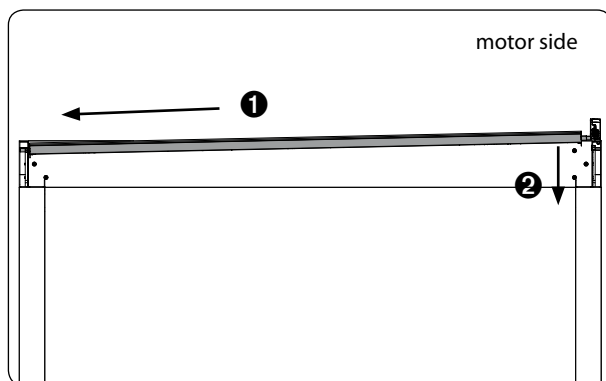
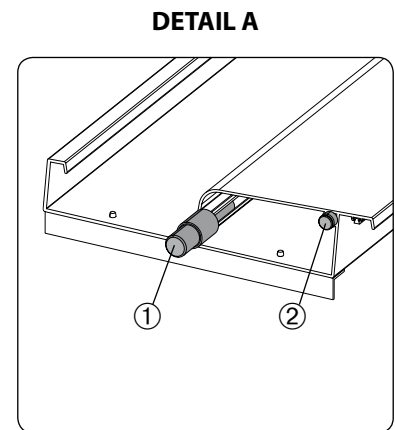
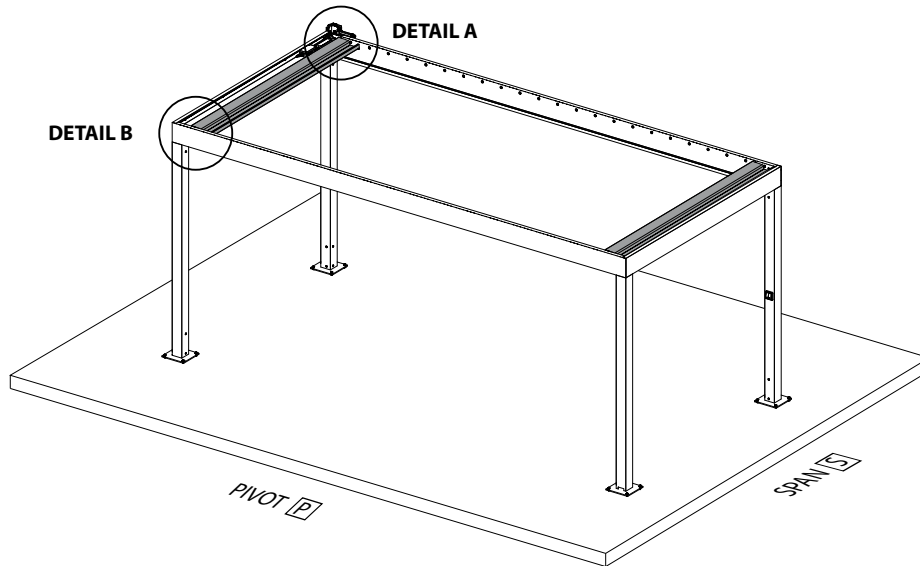

### Step 3: Installation of the driving profile

1. Attach the driving profile ④ to the little pin ② of the 2 outer blades (**DETAIL C**). Secure with a clips ⑤. Place the clips with the knob faced to the outside.
2. Secure the motor to the driving profile (**DETAIL D**)
  - Put the pin ⑥ through the bracket of the driving profile and through the motor head.
  - Secure with a nut ⑦ faced to the outside and secure the bracket with a clips ⑧.

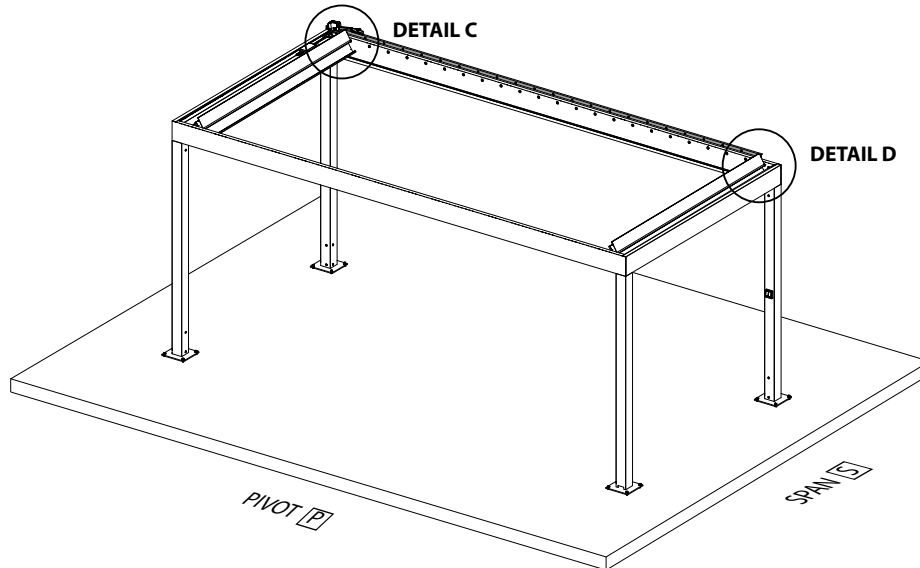

**DETAIL C**

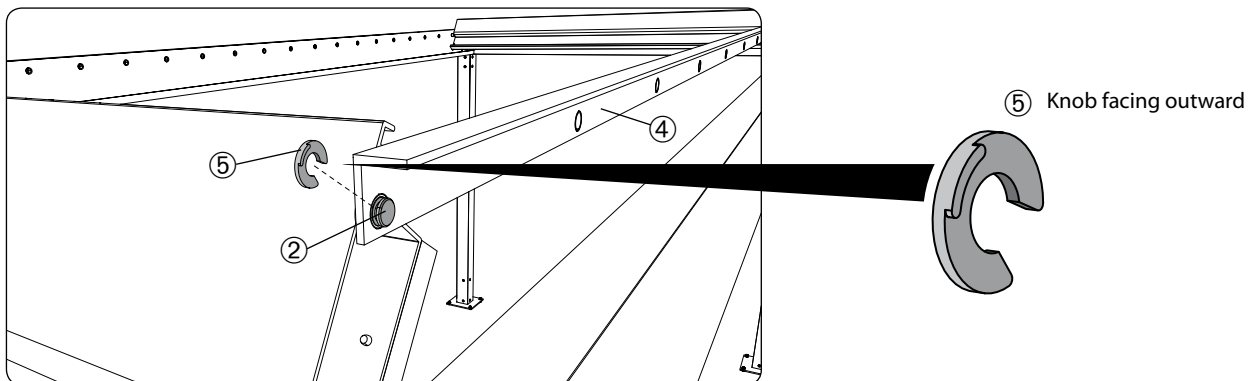



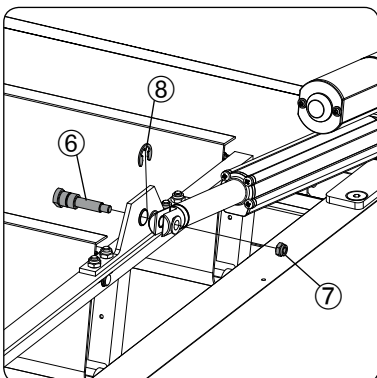













**DETAIL D**







## 6.3 Connecting the control box + setting the controls

### 1. Blades

1. Connect the transformer to the mains (230 Volt AC)
2. Press longer than 2 sec. on the PROG key of the general control box **(DETAIL A)** until S1 LED flashes  
(The drive makes an outgoing or incoming movement for confirmation)
3. Quickly press the PROG key **(DETAIL A)** to select the desired output S1 or S2. S1 is to control the blades
4. On Telis RTS Transmitter 4- or 16-channels, select the desired channel
5. Press simultaneously  +   
(The drive makes an outgoing or incoming movement for confirmation)
6. Check direction:
  -  = Open
  -  = Close
 If this is not the case, invert the direction by pressing  for more than 5 seconds  
(The drive makes an outgoing or incoming movement for confirmation)  
Recheck the direction
7. Open the blades completely (press and hold )
8. Confirm the opened position by pressing simultaneously  +   
(The blades closes automatically.)
9. Stop movement by pressing 
10. Close the blades completely (press and hold )
11. Confirm the closed position by pressing simultaneously  +   
(The blades opens automatically)
12. Stop movement by pressing 
13. Open the blades to the position desired in case of snow (press and hold  or )
14. Confirm the snow position by pressing  for more than 2 seconds  
(The drive makes an outgoing or incoming movement for confirmation)
15. Briefly press the PROG button on the back side of the Telis RTS transmitter **(DETAIL B)** until the drive makes an outgoing or incoming movement for confirmation
16. You can now operate the motor
17. Close the general control box
18. Place the general control box and transformer back in the frame profile.

See separate manual 'Automation Alba' for a detailed description

### 2. Lineo LED (Option)

1. Open the general control box
2. Press longer than 2 sec. on the PROG key of the general control box **(DETAIL A)** until S1 LED flashes  
(The drive makes an outgoing or incoming movement for confirmation)
3. Quickly press the PROG key **(DETAIL A)** to select the desired output S1 or S2. S2 is to control the LED
4. On Telis RTS Transmitter 4- or 16-channels, select the desired channel
5. Briefly press the PROG button on the back side of the Telis RTS transmitter **(DETAIL B)** until the LED goes ON or OFF
6. Close the general control box
7. Control LED:
  1. On (press  briefly)
  2. Off (press  briefly)
  3. Brightness + (long  press)
  4. Brightness - (long  press)

**DETAIL A**

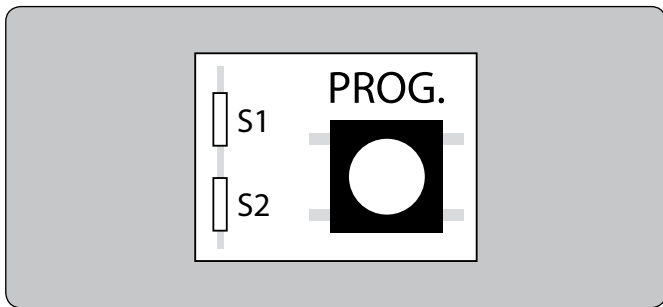

**DETAIL B**

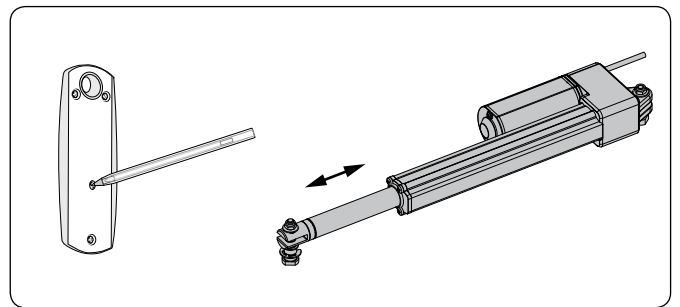

## 6.4 Installation remaining blades

Install the remaining blades in the frame and fix them to the driving profile ① (**DETAIL A**). Secure with a clips ②. Place the clips with the knob facing to the outside.

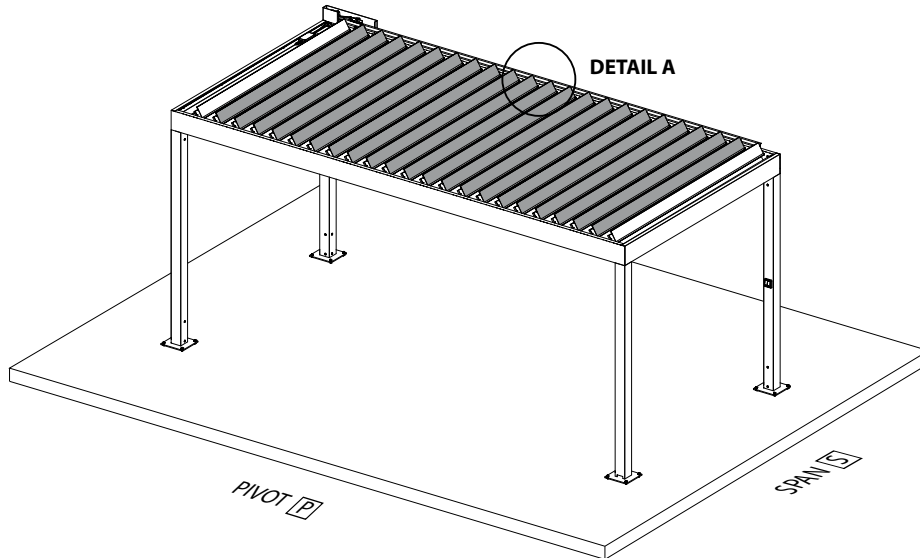

**DETAIL A**

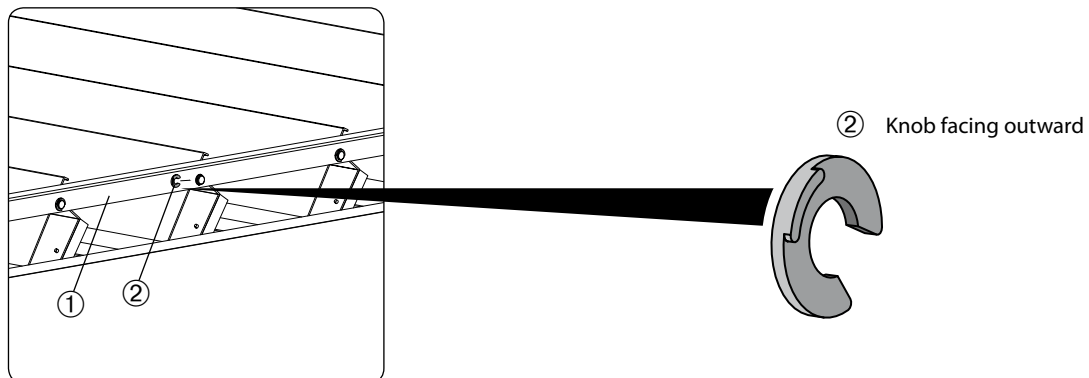

## 6.5 Fine-tuning motor

The position of the motor (**DETAIL A**) for the blades can be adjusted. If the blades are under too much tension after closing, or don't close properly, this can be adjusted by finetuning (**DETAIL B**) the position of the motor (max. 1 cm), i.e. by adjusting nuts DIN 934 – M10 in the desired direction by using a wrench n° 17.

**DETAIL A**

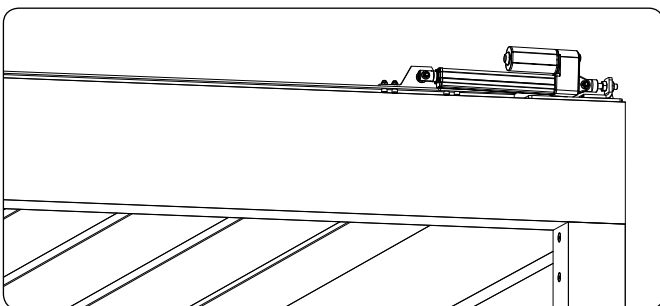

**DETAIL B**

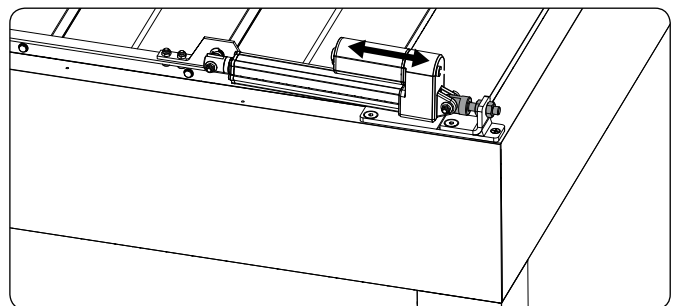

## 6.6 Installation reinforcement blades

Alba with **Pivot**  $\geq 432,5$  cm will be provided with **1 reinforcement blade**.

Alba with **Pivot**  $\geq 561,5$  cm will be provided with **2 reinforcement blades**.

1. **Recognition:** The pins of the reinforcement blade(s) ③ are thicker than the pins of the standard blades ④.
2. Cut out slots are provided in the Pivot frame profiles for the installation of the reinforcement blade(s) (**DETAIL B**).
3. Install the reinforcement blade(s) in the provided cut out slots.
4. Install both cover plates, 4 x 4 cm ⑤ (bearing side) and 3 x 4 cm ⑥ (motor side), by using the 4 screws DIN 7982 ST 3,5 x 16 (**DETAIL C**).  
We recommend sealing the cover plates with silicone to ensure water-resistance.

Reinforcement blade

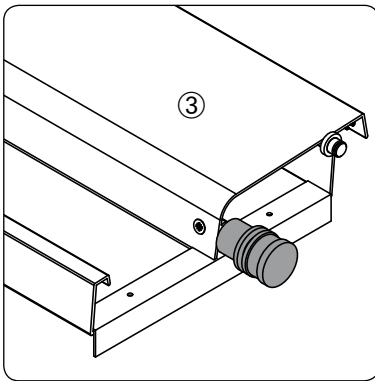

Standard blade

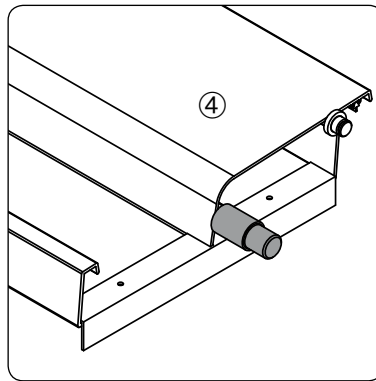

DETAIL B

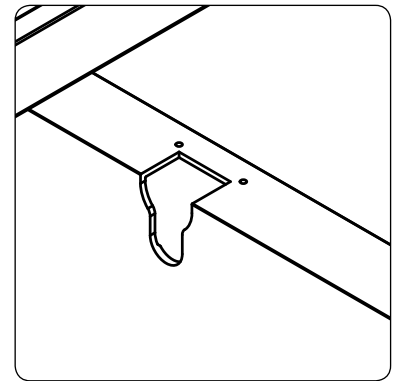

DETAIL C

Cover plate bearing side

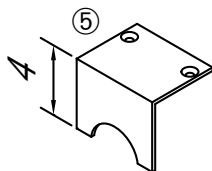

Cover plate motor side

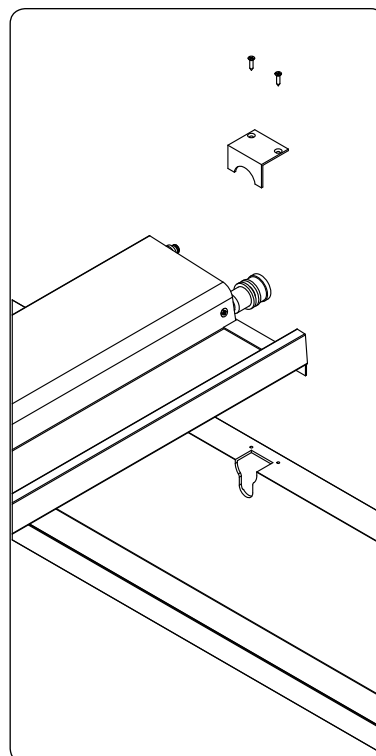
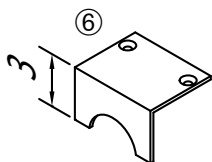

## 6.7 Finishing

A touch-up-pencil is provided for the finishing of the Alba. Use following instructions:

1. Clip the coverprofile ② onto the finishing profile ① to protect the electrical control box and transfo (**DETAIL C**).
2. Remove the little pot from the top screw. Put it aside.
3. Install the housing ③ for the motor (**DETAIL B & C**).
3. Pull the screw cap with brush and plastic ring out of the metal cartridge (do not turn).
4. Fill up the required coloured powder delivered in the joined pot.
5. Stir the powder and basecoat with the brush.
6. Press screw cap & ring back into the metal cartridge.
7. Shake vigorously for about 1 minute so that you hear the ball.
8. Apply the ready-for-use coat in thin layers where needed.

**DETAIL A**

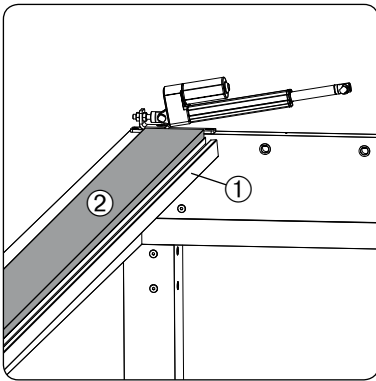

**DETAIL B**

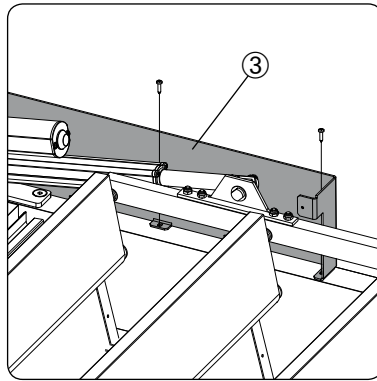

**DETAIL C**

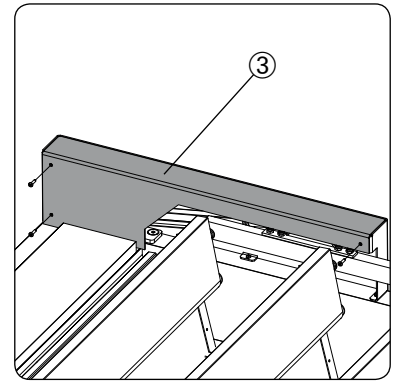

## 7 Final check

1. Check that all screws, bolts and nuts are firmly tightened.
2. Check the function of the blades.

# INSTALLATION LIGHTS

## 1 Installation Alba Light

The cable(s) of the LED-blade(s) (A) are provided in the Pivot frame profile at the motor side.

Put the cable(s) through the provided cut-away (B) while the connection between the Pivot & Span frame profiles is being made (6.1 step 5 installation instructions Alba).

Connect the connection fiche of the LED-blade (C) to the connection fiche of the control box of the LED lighting (D).

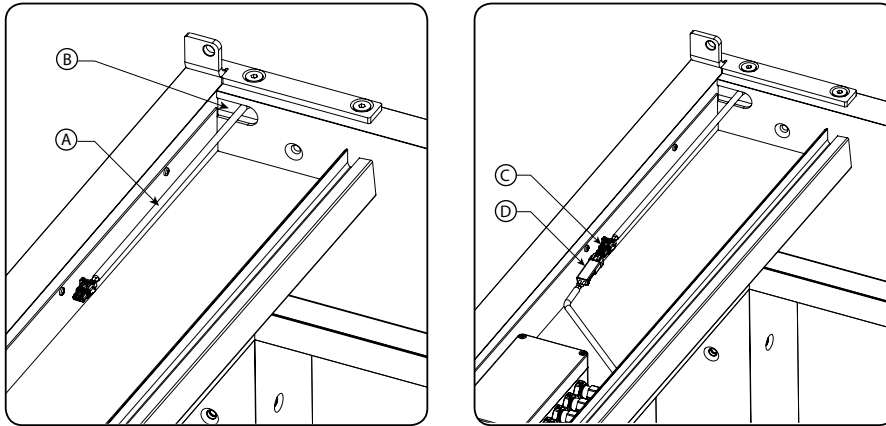

Position the LED-blades on the desired position in the frame. Connect the connection fiche of the LED-blade (A) with the fiche of the cable that comes out of the frame profile (B). Slid the bearing (C) over the connected connection fiches (D).

**Caution:**

Make sure the connection fiches are still connected. Repeat this step in case you need to connect several LED-blades.

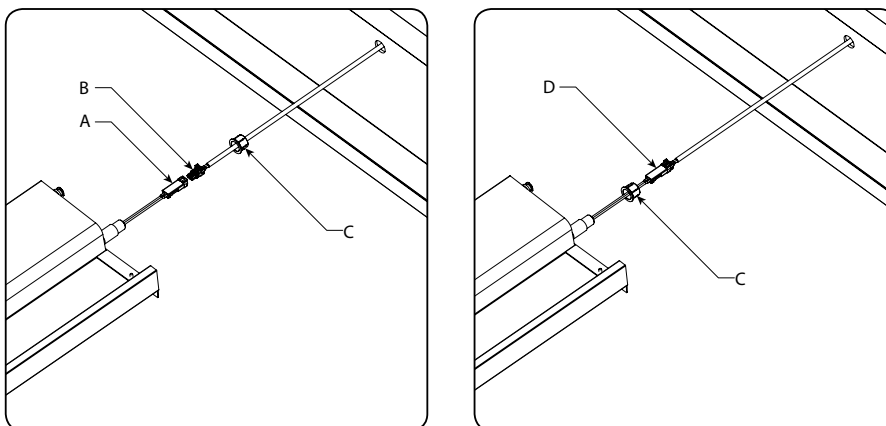

Connect the control box to the mains voltage (230 Volt AC), and check the operation of the LED lighting.

**Attention:** Connect the LED lighting to a separate electrical circuit

Put the connection fiches through the hole in the Pivot frame profile and place the bearing **A** in the hole.

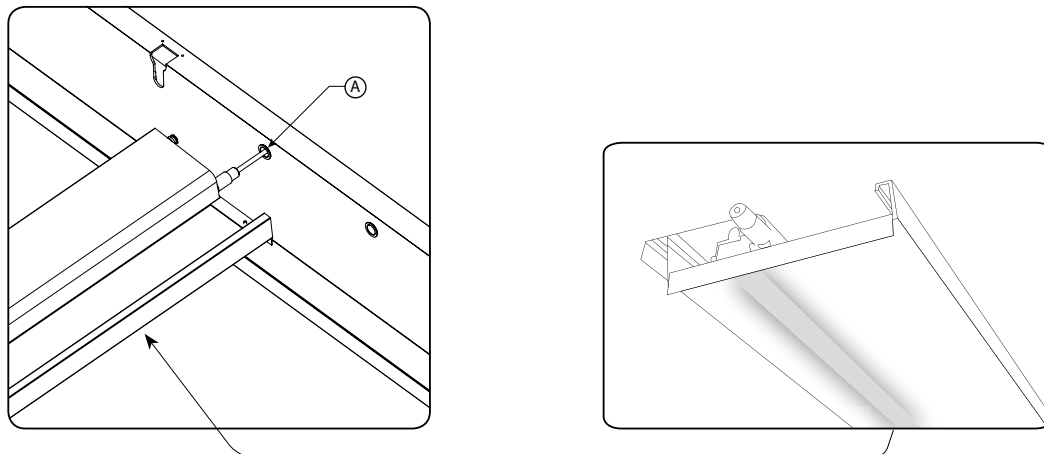

Install the blade in the frame and follow the further instructions in the Alba installation-instructions (6.2 Step2).

### Final check

Check that all screws, bolts and nuts are firmly tightened.

Check the operation of the LED-blades.

### Position LED-blade Alba

**Position cable (L = 7,5 m) in Pivot frame profile at the motor side in case of an Alba with LED-blades (counting from motor side)**

Pivot	Blades	Position in case of 1 LED-blade	Position in case of 2 LED-blades	Position in case of 3 LED-blades
260,5 cm	11	6	4 + 8	3 + 6 + 9
282 cm	12	6	4 + 8	3 + 6 + 9
303,5 cm	13	7	4 + 9	4 + 7 + 10
325 cm	14	7	5 + 10	3 + 7 + 11
346,5 cm	15	8	5 + 10	4 + 8 + 12
368 cm	16	8	5 + 11	4 + 8 + 12
389,5 cm	17	9	6 + 12	4 + 9 + 14
411 cm	18	9	6 + 12	4 + 9 + 14
432,5 cm	19	10	6 + 13	5 + 10 + 15
454 cm	20	10	7 + 14	5 + 10 + 15
475,5 cm	21	11	7 + 14	5 + 11 + 17
497 cm	22	11	7 + 15	5 + 11 + 17
518,5 cm	23	12	8 + 16	6 + 2 + 18
540 cm	24	12	8 + 16	6 + 13 + 20
561,5 cm	25	13	8 + 17	6 + 13 + 20
583 cm	26	13	9 + 18	6 + 13 + 20
604,5 cm	27	14	9 + 18	7 + 14 + 21





**Corradi Srl**

Via G. Brini, 39 • 40128 Bologna, Italy

T +39 051 4188 411 • F +39 051 4188 400

E [info@corradi.eu](mailto:info@corradi.eu)

[www.corradi.eu](http://www.corradi.eu)